

DTL-IceNet: A Dual-Task Learning Architecture with Multi-Scale Fusion Mechanisms for Enhanced Ice Detection on Transmission Lines

Yufei Fu¹, Yang Cheng¹, SongYuan Cao², Ling Tan³, Jiaxin He³, Mengya Wang³, Wenjie Zhang³

¹Electric Power Research Institute, State Grid Anhui Electric Power Company Ltd., Hefei, China.

²State Grid Anhui Electric Power Company Ltd., Hefei, China.

³School of Computer Science, Nanjing University of Information Science and Technology, Nanjing, China.

Correspondence to: Wenjie Zhang (zhangwenjie@nuist.edu.cn)

Abstract. Icing on transmission lines can significantly impact the stable operation of the power system. Deep learning-based ice image recognition is effective but remains vulnerable to background interference and noise, degrading accuracy. Moreover, when detecting ice thickness, the 2D nature of ice images introduces spatial limitations in representing the 3D ice state, which can lead to detection errors caused by a single viewpoint. To tackle the aforementioned challenges, this paper proposes DTL-IceNet (Dual-Task Learning Ice Detection Network), a transmission line icing detection network based on a dual-task learning framework, designed to accurately identify both the type and thickness of ice on overhead transmission lines. DTL-IceNet incorporates a multi-branch structured ice coating recognition module, ResSepNet (Residual & Depth-Separable Convolution Network), which segments the background and conductor areas to mitigate the influence of background noise. Additionally, a semantic segmentation module, MOMSA-SegNet (MobileOne & Multi-Scale Attention Segmentation Network) is designed to segment the ice-covered areas in both the main and side views of the image. The multi-scale attention mechanism is employed to extract spatial features from the raw icing image. When calculating ice thickness, the multi-scale fusion and correction optimization are adopted to enhance the algorithm. Experimental results show that compared with other models, the proposed method achieves an improvement of 4.17 % in icing type identification accuracy and a MAPE of 11.82 % in icing thickness detection. The application of this approach is crucial for reducing the hazards caused by ice coating on transmission lines and improving the stability of the power grid.

1 Introduction

Extreme weather can lead to ice accumulation on power lines, significantly increasing the risk of incidents such as conductor breakage or tower collapse, thereby threatening the stability of the power supply. Therefore, real-time monitoring of ice type, thickness, and other conditions on transmission lines is essential for ensuring the safe and stable operation of the power grid.

Traditional ice detection methods primarily rely on physical sensors and manual inspections (Zhang et al., 2024). However, these methods often suffer from high costs, low real-time performance, and limited detection accuracy, making them insufficient for effective ice monitoring in complex environments. In recent years, with the rapid advancement of deep learning and computer vision technologies, intelligent detection methods based on the YOLO

34 model have increasingly become an effective approach. Chen et al. (2024) proposed a transmission line icing detection
35 method based on YOLOv8. They utilized the ghost shuffle convolution to reduce model parameters and improve
36 computational efficiency. Additionally, they incorporated the BiFormer attention mechanism and the Wise-IoUv3 loss
37 function to enhance the model's accuracy in detecting ice-covered areas. Kong et al. (2024) integrated the GE attention
38 module into YOLOv8 to enhance detection accuracy and replaced the concatenate structure in the original network
39 with the BiFPN feature fusion module. This modification enables the detection of ice-covered areas on power trans-
40 mission lines in complex backgrounds. Although the YOLO-based detection algorithm effectively locates ice-covered
41 areas on transmission lines, it fails to detect and assess key information, such as ice contours and thickness. Building
42 on this, Lu (2024) proposed the Canny-UNet model by enhancing YOLOv8 with EfficientViT (Liu et al., 2023), and
43 integrating the Canny edge detection algorithm along with semantic segmentation technology, which further enabled
44 accurate segmentation of ice contours. Similarly, He et al. (2023) applied the ProtoNet segmentation model to the
45 detection results of the improved YOLOv5s, enabling the segmentation of ice-covered areas based on target detection.
46 Similarly, He et al. (2023) utilized the GrabCut algorithm in conjunction with target detection to identify and segment
47 transmission line insulators.

48 Although the aforementioned methods employ edge detection and semantic segmentation techniques to segment
49 and detect the contours of ice-covered regions, the calculation of ice thickness primarily depends on edge detection
50 algorithms. Wang et al (2023) proposed an image denoising algorithm based on adaptive switching median filter.
51 Building upon this, an optimized Canny operator was employed to detect the edges of the ice-covered conductor's
52 contour. The computed ice thickness was then compared with the results obtained from optical fiber detection, yielding
53 an average error of just 4.10 %. Yang et al. (2023) proposed an ice monitoring method integrating image edge detection
54 and normal detection. The approach first preprocesses micro-photographed images of transmission lines, applies al-
55 gorithms such as eight-neighborhood tracking to detect edges and determine the longest side of the conductor, and
56 designs an ice thickness detection method based on edge normal detection. Experimental results indicate that the
57 relative error of real-time conductor ice thickness measurements using this method does not exceed 9 %. He et al.
58 (2023) proposed a novel measurement method for thickness of uneven icing on transmission line in complex back-
59 ground. Their method involved image grizzling, median filter denoising, and maximum inter-class variance method
60 to analyze the images. By integrating the result-domain characteristics of transmission line icing information and
61 background noise, they extracted the re-icing transmission line. Finally, the vertical line approximation method was
62 applied to determine the re-icing thickness. Such methods leverage edge detection techniques to enhance the extraction
63 of ice cover information and initially estimate the corresponding ice thickness. However, they exhibit limited robust-
64 ness to environmental interferences such as lighting variations and haze and fail to account for the three-dimensional
65 spatial distribution of the conductors. Consequently, when encountering irregular ice formations, these methods may
66 yield larger errors.

67 Accurately identifying the type of ice on transmission lines is crucial for improving ice detection capabilities. In
68 the field of ice classification, some researchers analyze monitoring data to distinguish different ice types. Fan et al.
69 (2018) analyzed the collision rate of water droplets on conductors with varying diameters and employed the standard
70 ice thickness normalization method to quantify the extent of conductor icing. Hao et al. (2023) analyzed multi-source

71 data and applied the KNN algorithm to classify four distinct types of ice cover. Chen et al. (2024) proposed a method
72 to monitor the status of ice-covered transmission lines based on conductor end displacement, which can aptly capture
73 the stress characteristics of transmission lines in frozen rain environments. Due to limitations in monitoring data and
74 conditions, these methods face significant constraints. In recent years, visual image-based recognition technology has
75 advanced rapidly. Most research on ice recognition has focused on sea ice, river ice, and road ice (Liu et al., 2025;
76 Ansair et al., 2024; Gui et al., 2023), achieving excellent detection performance. However, studies on ice type recog-
77 nition for transmission lines remain scarce. This is partly due to the challenges associated with capturing ice images
78 of transmission lines and partly due to the interference caused by complex background noise in such images, which
79 must be accounted for in recognition processes.

80 Beyond ice physical parameters and imagery, the accuracy of transmission line ice detection can be further enhanced
81 by incorporating environmental data. Numerous studies have demonstrated that meteorological factors, such as wind
82 and humidity, are closely correlated with conductor icing (Dong et al., 2022; Meng et al., 2025; Han et al., 2024),
83 offering valuable insights for ice thickness detection. Therefore, to address the challenges of low accuracy in ice type
84 recognition and thickness detection for transmission lines, this paper proposes DTL-IceNet (Dual-Task Learning Ice
85 Detection Network), a dual-task learning framework designed to enhance the performance of both ice coating recog-
86 nition and thickness detection. DTL-IceNet employs a multi-branch ice coating recognition module to separately ex-
87 tract spatial feature information of both the background and ice-covered regions, thereby determining the ice type.
88 Simultaneously, a multi-scale attention-based semantic segmentation module is utilized to segment the ice-covered
89 areas. Finally, the model integrates ice type recognition, ice segmentation results, and key meteorological factors to
90 optimize ice thickness estimation, yielding more accurate identification of ice types and thickness on transmission
91 lines. The main contributions of this paper are as follows:

92 (1) To address the issue of low ice thickness detection accuracy caused by the irregular shape of ice on transmission
93 lines and complex environmental conditions, this paper proposes a dual-task learning framework, DTL-IceNet. The
94 framework enhances ice thickness detection performance by leveraging ice type classification and key meteorological
95 elements to assist ice segmentation. The proposed framework incorporates an ice coating recognition module, Res-
96 SepNet (Residual & Depth-Separable Convolution Network), an icing region segmentation module, MOMSA-SegNet
97 (MobileOne & Multi-Scale Attention Network), and an ice thickness optimized calculation module. By integrating
98 ice segmentation results with ice types and key meteorological factors through multi-scale fusion, the framework
99 refines ice thickness estimation. Through the fusion of multi-source heterogeneous data and the multi-scale fusion of
100 image classification and segmentation techniques, the reliance on a single ice contour for thickness estimation is elim-
101 inated, significantly enhancing detection accuracy.

102 (2) To address the challenge of incomplete information extraction and utilization in transmission line ice images
103 due to background noise interference, such as fog and light noise, a ResSepNet ice coating recognition module is
104 developed. This module integrates a nested residual structure and depthwise separable convolution to segment the ice
105 image into an upper background area and a lower conductor area. Additionally, three branches are designed to extract
106 features from the entire image, background, and conductors separately, effectively mitigating the impact of back-
107 ground noise.

108 (3) Considering the limitations of two-dimensional ice images in representing the spatial distribution of three-dimensional ice, which may lead to detection errors, this study designs the MOMSA-SegNet icing region segmentation
 109 module. The module incorporates an improved MobileOne encoder and a multi-scale attention mechanism to segment
 110 the ice region from both the main and side perspectives of the image, thereby enhancing the information capture
 111 capability of a single perspective. Additionally, a skip connection structure and multi-scale attention mechanism are
 112 employed to comprehensively extract spatial features from the raw icing image, further improving segmentation accuracy.
 113
 114

115 2 Method

116 The detection of ice in transmission line images primarily involves two tasks: ice type recognition and ice thickness
 117 detection. This paper presents DTL-IceNet, a dual-task learning framework for ice detection, designed to achieve ice
 118 type recognition and ice thickness detection for transmission lines. Through the meticulous design of various modules,
 119 the proposed framework effectively addresses the limitations in the accuracy of ice type recognition and thickness
 120 detection. The overall framework structure of DTL-IceNet is illustrated in Fig. 1.

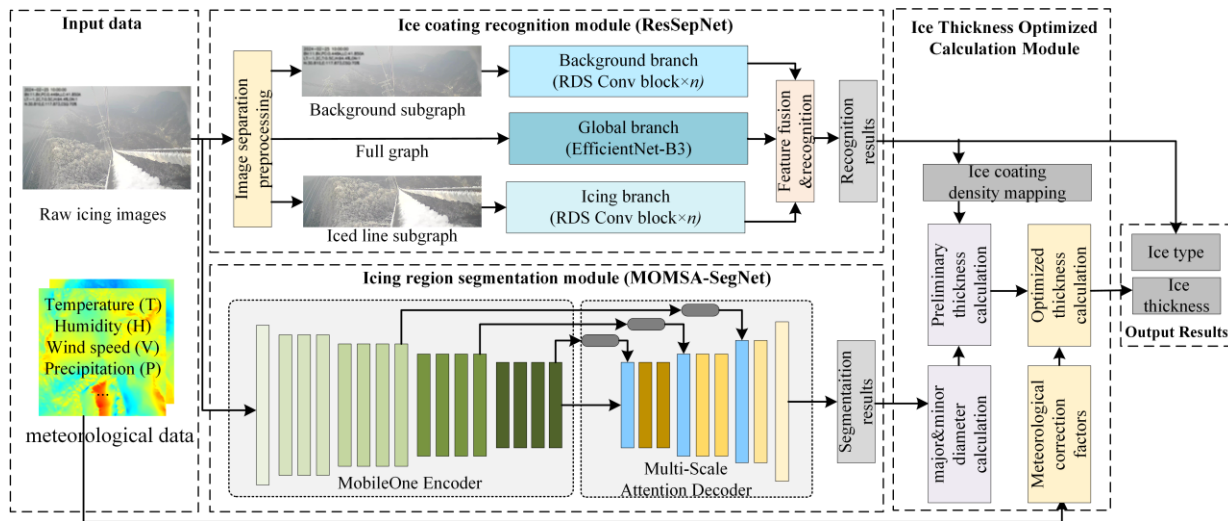

121
 122 **Figure 1.** DTL-IceNet overall framework structure.

123 Note. For details on the ice coating recognition module, please refer to Section 2.2; for details on the icing region segmentation
 124 module, please refer to Section 2.3; for details on the equivalent thickness optimized calculation module, please refer to Section
 125 2.4.

126
 127 DTL-IceNet primarily consists of three components: the ice coating recognition module (ResSepNet), the icing region
 128 segmentation module (MOMSA-SegNet), and the ice thickness optimized calculation module. In the ResSepNet mod-
 129 ule, the raw icing image undergoes preprocessing to generate the background subgraph and the iced line subgraph.
 130 Along with the full ice-covered graph, three branches are employed to extract features from different spatial regions,
 131 which are then fused to determine the ice type. In the MOMSA-SegNet module, the raw icing image is processed
 132 through a multi-scale attention-based semantic segmentation network to segment the ice-covered region from both the
 133 main view and the side view. In the ice thickness optimized calculation module, the ice coating recognition results

134 and icing region segmentation results are integrated, and key meteorological data is introduced for correction and
 135 optimization to obtain equivalent ice cover thickness values, thereby realizing the ice type recognition and thickness
 136 detection tasks. The subsequent sections will provide a detailed description of the ResSepNet module, MOMSA-
 137 SegNet module, and the ice thickness optimized calculation module.

138 **2.1 ResSepNet**

139 The ice coating recognition module, ResSepNet, consists of a background branch, an icing branch, and a global branch.
 140 It is capable of recognizing four types of icing: ice-free, glaze, rime, and mixed rime. To mitigate background noise
 141 interference, the original image is divided into a background subgraph and an iced line subgraph. The background and
 142 ice-covered branches extract features from their respective regions, while the global branch utilizes a transfer learning
 143 model to capture the overall ice-covered features of the entire image. By employing a multi-branch structure, ice-
 144 covered features at different spatial scales are normalized, fused, and recognized to produce the final recognition result.
 145 The model structure of ResSepNet is shown in Fig.2, which mainly includes an ice segmentation preprocessing module
 146 and a feature extraction and recognition module.

Answer to reviewer 1.
 Comments 6:

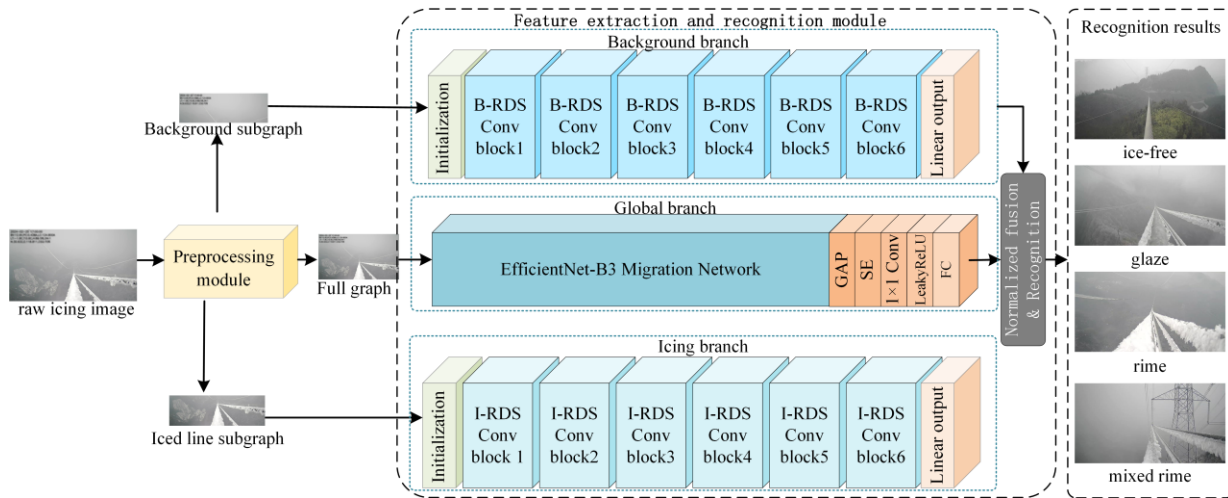

147
 148 **Figure 2.** Model structure of ResSepNet.

149 **2.1.1 RDS Convolutional Block**

150 To enhance the feature extraction performance of the model in complex icing scenarios, this paper incorporates mul-
 151 tiple RDS convolution blocks into ResSepNet, utilizing a nested residual structure and depthwise separable convolu-
 152 tion. These blocks serve as the core feature extraction modules in both the background and icing branches. The struc-
 153 ture of the RDS convolution block is illustrated in Fig. 3. The convolution block in the background branch is referred
 154 to as B-RDS, while the one in the icing branch is denoted as I-RDS. Both branches adopt similar network architectures
 155 (as show in Fig. 2). Figure 3 presents the structure of a single RDS convolution block.

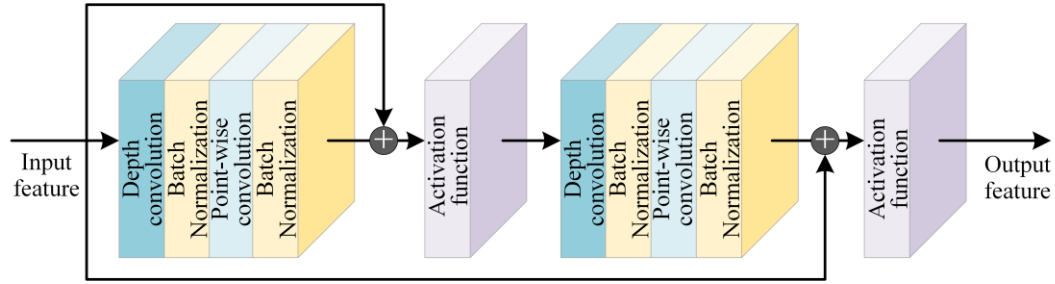

156
157 **Figure 3.** A single RDS convolution block.

158
159 The nested residual structure in the RDS convolutional block incorporates skip connections, enabling gradients to
160 propagate directly from shallow layers to deeper layers. This effectively mitigates the gradient vanishing problem
161 while preventing network overfitting and degradation. By employing multiple nested residual blocks, the model cap-
162 tures complex features at deeper levels while preserving shallow features, thereby enhancing its capability to extract
163 intricate features in real-world ice-covered scenarios. On the other hand, the RDS convolution block incorporates
164 depthwise separable convolution, a decomposition method that effectively reduces the number of parameters in con-
165 volution operations. This significantly enhances the computational efficiency of the network, resulting in a more com-
166 pact and responsive model. Its flexibility allows deployment in resource-constrained environments, facilitating dis-
167 tributed processing and real-time computation, making it particularly suitable for transmission line ice detection tasks.

168 2.1.2 Multi-Branch Feature Extraction and Fusion Recognition Module

169 To mitigate the interference of background noise in ice-covered images, ResSepNet employs a three-branch structure
170 comprising a background branch, a global branch, and an icing branch. By extracting local and global features at
171 multiple scales, it effectively reduces the impact of background noise on recognition performance. The raw icing
172 image undergoes preprocessing to generate a background subgraph in the upper region and an iced line subgraph in
173 the lower region. The background subgraph is fed into the background branch to focus on extracting feature infor-
174 mation from the background environment. The iced line subgraph is directed to the icing branch to emphasize the
175 extraction of ice feature information in the transmission line area. Meanwhile, the complete image is directly input
176 into the global branch to capture overall ice feature information. The global branch feature extraction network utilizes
177 EfficientNet-B3 (Tan & Le, 2019) with a migration structure. EfficientNet-B3 achieves a balance between model size
178 and feature extraction capability, ensuring effective feature extraction without excessive computational resource con-
179 sumption. To adapt to the transmission line icing scenario, the ResSepNet global branch enhances EfficientNet-B3 by
180 incorporating an adaptive output layer. This layer primarily consists of a global average pooling (GAP) layer, a
181 squeeze-and-excitation (SE) module (Hu et al., 2018), a 1×1 convolutional layer, a LeakyReLU activation function,
182 and a fully connected (FC) output layer.

183 After extracting features from the background branch, icing branch, and global branch, ResSepNet normalizes and
184 sums the ice-covered features output by the three branches to mitigate amplitude differences among features from
185 different branches. This process is mathematically represented by (1):

$$f_{mixed} = \frac{f_{bg}}{\|f_{bg}\|} + \frac{f_{ice}}{\|f_{ice}\|} + \frac{f_{main}}{\|f_{main}\|} \quad (1)$$

where $\|f\|$ denotes the L2 norm of the feature vector, and f_{bg} , f_{ice} , and f_{main} represent the output features of the background branch, icing branch, and global branch, respectively. f_{mixed} represents the final multi-branch fusion output feature, which serves as the icing type recognition result of the transmission line, including ice-free, glaze, rime, and mixed rime.

2.2 MOMSA-SegNet

The icing region segmentation module, MOMSA-SegNet, employs the improved MobileOne (Vasu et al., 2023) model as its encoder and incorporates a multi-scale skip connection structure in the decoder. This design forms a semantic segmentation network with a large encoder-small decoder architecture, enabling precise segmentation of the ice-covered regions on transmission lines. The module structure is illustrated in Fig. 4.

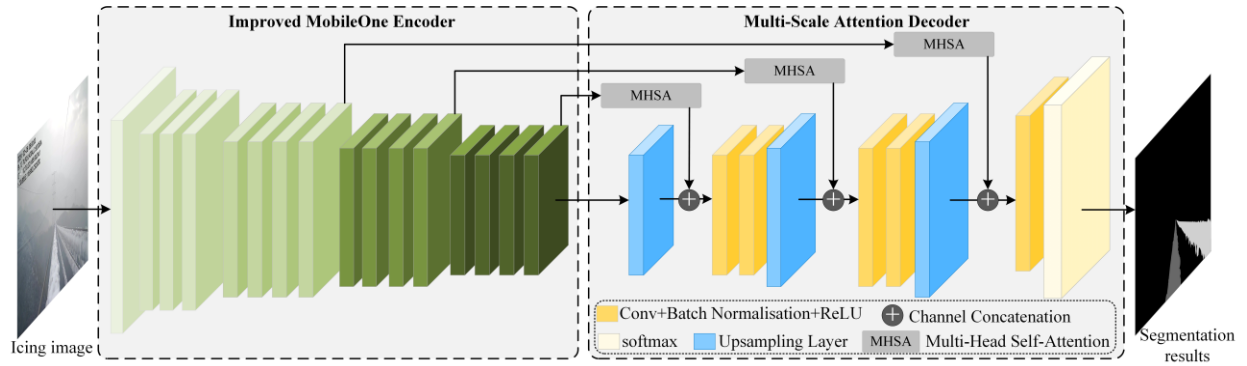

196
197 **Figure 4.** MOMSA-SegNet module structure.

198 To address the issue of information loss resulting from a single perspective, which can reduce ice thickness detection
199 accuracy, MOMSA-SegNet segments the transmission lines from both the main and side perspectives in the raw icing
200 image. This segmentation leverages the multi-split transmission line structure to capture ice information more com-
201 prehensively. The definitions of the main perspective line and side perspective line in the raw icing image are illus-
202 trated in Fig. 5.
203

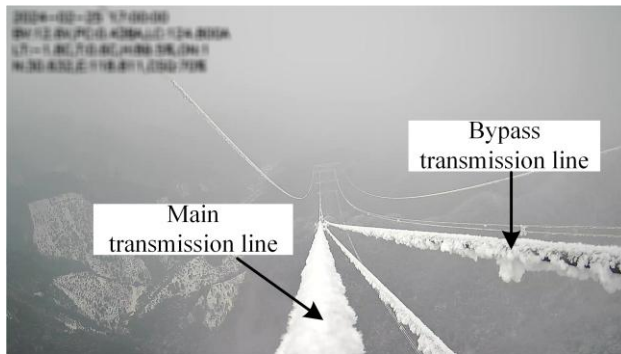

204
205 **Figure 5.** Schematic diagram of transmission line from different perspectives.

206 2.2.1 Improved MobileOne Encoder

207 MobileOne employs a re-parameterized convolutional structure, enabling the transformation of complex branched
208 architectures into a single, efficient convolutional operation during the inference phase. This significantly reduces
209 computational overhead and inference latency. Furthermore, MobileOne is designed with hardware adaptability in
210 mind, ensuring efficient execution on low-power devices. This feature is particularly crucial for edge devices, such as
211 pole tower ice monitoring systems, where model deployment is required. Moreover, the convolutional structure of the
212 MobileOne model exhibits strong capability in capturing local details, making it well-suited for the fine segmentation
213 of ice-covered regions. Given the complexity of ice-covered images of power transmission lines—caused by factors
214 such as lighting variations, haze, and background clutter—this study enhances the original MobileOne by enlarging
215 the dilation rate in its feature encoding module to expand the receptive field (see the left side of Fig. 4). Additionally,
216 multi-scale features are extracted from multiple intermediate layers. By integrating a multi-head attention mechanism,
217 a multi-scale skip connection structure is designed to provide the decoder with contextual spatial features at different
218 scales, thereby enhancing segmentation accuracy in complex ice-covered scenarios.

219 2.2.2 Multi-scale Attention Decoder

220 The multi-scale attention decoder primarily consists of multiple multi-head self-attention (MHSA) sub-modules, con-
221 volutional layers, and upsampling layers. It extracts feature maps from various intermediate layers of the improved
222 MobileOne encoder, as illustrated in Fig. 4. Each feature map is first processed by an MHSA sub-module, after which
223 the self-attention output features are concatenated with the corresponding decoder layer at the same feature scale,
224 thereby forming the multi-scale attention decoder structure. The architecture of the MHSA sub-module is depicted in
225 Fig. 6.

226 The detailed feature processing procedure of the MHSA sub-module can be expressed by equation (2):

$$227 \quad output = X + Conv(Concat(\text{soft max}(\frac{Q_i K_i^T}{\sqrt{d_k}})V_i)_{i=1}^k W^o) \quad (2)$$

228 where *output* represents the output feature, while X denotes the input feature, which undergoes a linear transfor-
229 mation to obtain the query (Q), key (K), and value (V) matrices. Q, K, and V are divided into *h* heads, with each head
230 having its own transformation parameters Q_i , K_i , V_i . The attention weight matrix is computed using function

231 *soft max*, where $\frac{1}{\sqrt{d_k}}$ serves as a scaling factor to prevent gradient vanishing. The attention weight matrix is then

232 multiplied by V_i to obtain the output for each head, denoted as $\text{soft max}(\frac{Q_i K_i^T}{\sqrt{d_k}})V_i$. Subsequently, the attention

233 outputs of all heads are concatenated using function *Concat*, followed by a linear transformation W^o that remaps
234 the transformed features back to the original feature space. To further enhance local feature extraction, MHSA applies

235 an additional convolutional layer (Conv) after the linear transformation, reinforcing the model’s capability to extract
 236 fine-grained local features.

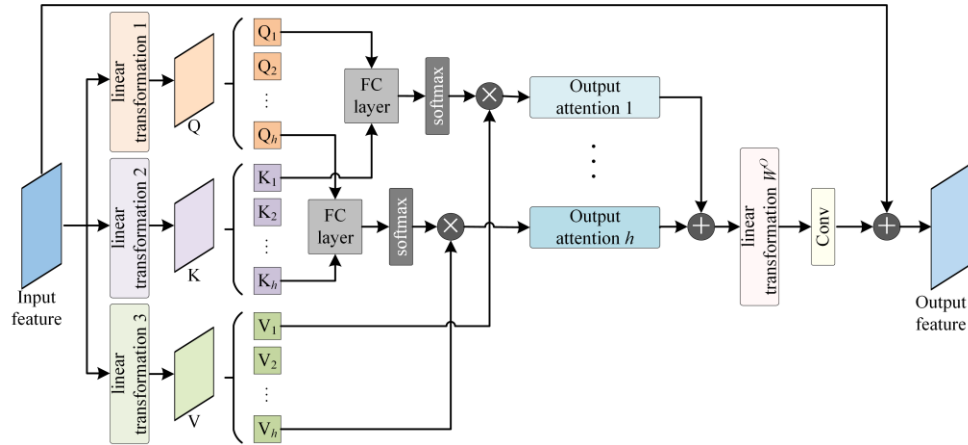

237
 238 **Figure 6.** MHA submodule.

239
 240 The multi-scale attention decoder integrates the features from each MHA output with the original input X through
 241 multiple residual structures. This approach preserves the original input information, enhances the model’s capability
 242 to extract contextual features, and improves its overall stability.

243 2.3 Ice Thickness Optimized Calculation Module

244 The dual-task learning framework proposed in this paper simultaneously outputs both ice type and ice thickness. The
 245 output of the ice coating recognition module serves not only as a final result but also as a key input for ice thickness
 246 estimation. The ice thickness optimized calculation module first performs an initial ice thickness estimation based on
 247 the identified ice type and segmentation results. Subsequently, key meteorological data are incorporated to refine the
 248 calculation, yielding an optimized ice thickness. Given that actual ice accumulation on transmission lines is typically
 249 uneven and irregularly shaped, the equivalent ice cover thickness is adopted as the final representation in the calcula-
 250 tion.

251 In the preliminary estimation of ice thickness, it is essential to determine the major and minor axes of the ice-
 252 covered cross-section. First, the pixel area of the ice-covered region in both the main view and side view of the original
 253 ice image is obtained based on the segmentation results from MOMSA-SegNet. Given the known wire diameter, the
 254 major and minor axes of the ice-covered cross-section can be estimated by comparing the pixel area of the bare wire
 255 in the same transmission line under an ice-free condition. The parameters of the ice-covered cross-section are illus-
 256 trated in Fig. 7, where d represents the bare wire diameter, and a and b denote the major and minor axes of the
 257 ice-covered cross-section, respectively.

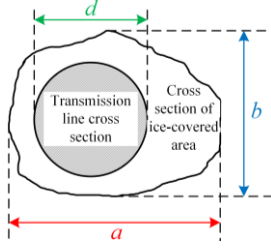

258
259 **Figure 7.** Schematic diagram of ice cross-section parameters.

260
261 Based on the icing type results from the ice coating recognition module, the corresponding icing density can be deter-
262 mined. Subsequently, the icing density is combined with the major and minor axes of the icing cross-section to perform
263 an initial estimation of the equivalent ice cover thickness.

264 2.3.1 Calculation of Equivalent Ice Cover Thickness

265 According to the layout specifications of overhead transmission lines, the main view line and the side view line are
266 positioned on the same horizontal plane. Therefore, the major and minor diameters can be determined by analyzing
267 the icing conditions of both lines.

268 The calculation of the major diameter a is given by (3):

$$269 \quad a = \frac{\sum_{x_{ice}=1}^W \sum_{y_{ice}=1}^H S(x_{ice}, y_{ice})}{\sum_{x_{wire}=1}^W \sum_{y_{wire}=1}^H S(x_{wire}, y_{wire})} \times d \quad (3)$$

270 where $S(x, y)$ denotes the pixel value at coordinate (x, y) in the segmentation result generated by MOMSA-Se-

271 gNet. $\sum_{x_{ice}=1}^W \sum_{y_{ice}=1}^H S(x_{ice}^A, y_{ice}^A)$ represents the total number of pixels in the segmented ice-covered area, while

272 $\sum_{x_{wire}=1}^W \sum_{y_{wire}=1}^H S(x_{wire}^A, y_{wire}^A)$ denotes the total number of pixels in the bare wire area without ice. The minor axes b can

273 be computed using the same approach.

$$274 \quad T = \sqrt{\frac{\rho}{3.6}(ab - d^2) + \frac{d^2}{4}} - \frac{d}{2} \quad (4)$$

275 Based on the ice type identification result, the corresponding ice density ρ (Li et al.,2016) is determined. According
276 to (4), the irregular ice cross-section can be approximated as a regular circular cross-section with an equivalent area,
277 enabling the calculation of the equivalent ice thickness T .

278 2.3.2 Optimization Calculation of Ice Thickness

279 Due to factors such as the placement of the ice monitoring device, the shooting angle, and variations in ambient light
280 intensity, ice thickness estimates derived solely from ice images often exhibit certain errors. To address this issue, this

281 study incorporates meteorological data in addition to ice images, leveraging key surrounding meteorological factors
 282 to refine and optimize the initial ice thickness calculations. This approach ensures greater alignment with the actual
 283 freezing conditions and enhances the overall robustness of the algorithm.

284 This study maps the latitude, longitude, and image capture time recorded by the ice monitoring device to the corre-
 285 sponding environmental meteorological data from ERA5. This mapping enables the extraction of key environmental
 286 factors, including temperature T ($^{\circ}\text{C}$), relative humidity H (%), wind speed V (m s^{-1}), and precipitation P (mm h^{-1})
 287 (Xu et al.,2023), for each ice image. To refine the ice thickness estimation, a key meteorological correction factor
 288 is constructed using the Gradient Boosting Decision Trees (GBDT) algorithm and parameterized as shown in (5):

$$289 \quad f(T, H, V, P) = \exp[(-\alpha T) \cdot (1 + \beta H) \cdot (1 - \gamma V) \cdot (1 + \delta P)] \quad (5)$$

290 where α , β , γ and δ are correction parameters. $(-\alpha T)$ indicates that an increase in temperature leads to a de-
 291 crease in ice cover, $(1 + \beta H)$ indicates that ice coverage increases with increasing humidity, $(1 - \gamma V)$ signifies that
 292 high wind speed may result in a decrease in ice cover, and $(1 + \delta P)$ indicates that higher precipitation leads to greater
 293 ice thickness.

294 The correction parameters in (5) are determined using the GBDT algorithm. The environmental meteorological
 295 factors are used as input features, with the optimized ice thickness value serving as the output target variable. The
 296 input feature set $W = [T, H, V, P]$ and the target variable set Y_{true} are constructed. After normalizing the input fea-
 297 ture set W , the GBDT regression model is built, and Y_{true} is fitted. Assuming that the model's prediction value
 298 $F_0(w)$ is the mean value of the target variable, the pseudo residual value during the m -th iterative optimization
 299 process of the regression model can be expressed by (6):

$$300 \quad r_m^{(i)} = -\frac{\partial L(Y_{true}^{(i)}, F_{m-1}(w))}{\partial F_{m-1}(w)}, i = 1, 2, \dots, N \quad (6)$$

301 where N denotes the total number of samples and L represents the MSE loss function.

302 The pseudo residual value $r_m^{(i)}$ is used as the target variable to fit the decision tree and obtain the regression tree
 303 $h(w)$. The model update is expressed as:

$$304 \quad F_m(w) = F_{m-1}(w) + \xi \cdot h_m(w) \quad (7)$$

305 where ξ represents the learning rate, and $h(w)$ denotes the output of the m -th regression tree. After training, the
 306 optimized prediction model is obtained, and each correction parameter can be determined using (8):

$$307 \quad \alpha = \frac{\partial F_M(w)}{\partial T}, \beta = \frac{\partial F_M(w)}{\partial H}, \gamma = \frac{\partial F_M(w)}{\partial V}, \delta = \frac{\partial F_M(w)}{\partial P} \quad (8)$$

308 where $\frac{\partial F_M(w)}{\partial w}$ represents the sensitivity of the model prediction to the key meteorological factors. The model hy-

309 perparameters are adjusted based on accuracy requirements, and the correction process is iteratively optimized to

310 obtain the final key meteorological factor correction parameters. The optimized result for the equivalent ice thickness
311 T_f is given by (9):

$$312 \quad T_f = T \cdot f(T, H, V, P) \quad (9)$$

313 **3 Experiments**

314 This paper constructs a dataset using raw icing images provided by the power grid and conducts performance valida-
315 tion experiments on ice coating recognition and ice thickness detection algorithms. The related work primarily in-
316 volves constructing datasets for ice coating recognition and icing region segmentation, training and testing models
317 based on these datasets, evaluating model performance, and conducting comparative analyses with existing methods.
318 The experiments were conducted on a Windows 11 operating system equipped with an NVIDIA GeForce RTX 3090
319 GPU and 24 GB of memory. The proposed model was developed and tested using the PyTorch framework, followed
320 by related experiments.

321 **3.1 Experimental Plan and Evaluation Indicators**

322 To evaluate the effectiveness of the proposed method, experiments were conducted on ice coating recognition, ice
323 region segmentation, and ice thickness detection. The experimental plan includes: 1) Ablation studies to assess the
324 contribution of each branch in the ice coating recognition model, ResSepNet. 2) Performance comparison of Res-
325 SepNet with other mainstream classification models for ice type recognition. 3) Segmentation performance compari-
326 son between MOMSA-SegNet and other advanced segmentation models. 4) Transmission line icing state detection in
327 real-world scenarios using the proposed DTL-IceNet model.

328 To facilitate model training and testing for ice coating recognition and ice thickness detection, this paper utilizes
329 ice monitoring images captured by ice-viewing devices deployed in the power grid. Corresponding datasets are con-
330 structed based on ice coating recognition and ice thickness detection tasks to meet the training, validation, and testing
331 requirements of the proposed algorithm.

332 For the ice type recognition experiment, this paper primarily evaluates and compares model performance using
333 classification accuracy, precision, recall, F1-score, and the confusion matrix. The calculation formulas for each metric
334 are as follows:

$$335 \quad Accuracy = \frac{TP + TN}{TP + TN + FP + FN} \quad (10)$$

$$336 \quad precision = \frac{TP}{TP + FP} \quad (11)$$

$$337 \quad recall = \frac{TP}{TP + FN} \quad (12)$$

$$338 \quad F1 - Score = \frac{2 \cdot precision \cdot recall}{precision + recall} \quad (13)$$

339 where TP denotes the number of samples correctly classified as positive, TN denotes the number of samples cor-
340 rectly classified as negative, FP denotes the number of samples incorrectly classified as positive, and FN denotes
341 the number of samples incorrectly classified as negative.

342 For the icing region segmentation experiment, this paper primarily employs intersection over union (IoU), mean
343 IoU (MIoU), and mean pixel accuracy (mPA) to assess and compare the segmentation performance of the model. The
344 formulas for each metric are as follows:

$$345 \quad IoU = \frac{|A \cap B|}{|A \cup B|} \quad (14)$$

$$346 \quad MIoU = \frac{1}{N} \sum_{i=1}^N IoU_i \quad (15)$$

$$347 \quad mPA = \frac{1}{N} \sum_{i=1}^N \frac{P_i}{T_i} \quad (16)$$

348 where A represents the predicted target area, B represents the actual target area, $A \cap B$ denotes the overlapping
349 area between the two, $A \cup B$ denotes their total coverage area, P_i represents the number of correctly classified pix-
350 els for category i , and T_i represents the total number of actual pixels in category i .

351 3.2 Dataset

352 For the tasks of ice coating recognition and icing region segmentation, this paper constructs two datasets. The ice
353 coating recognition task focuses on classifying different types of icing on transmission lines. Therefore, a diverse set
354 of icing samples, including ice-free, glaze rime, and mixed rime, is selected from a large collection of original trans-
355 mission line icing images. During the data preprocessing stage, manual labeling is employed to classify each sample,
356 ensuring label accuracy and consistency. Subsequently, data cleaning is performed to remove blurry, abnormally cap-
357 tured, or incomplete images, retaining only clear and representative ice-covered samples. Finally, an ice coating recog-
358 nition dataset, IceType, consisting of 20,684 images, was constructed and divided into a training set, test set, and
359 validation set in a 6:2:2 ratio.

360 The ice thickness detection task is primarily accomplished through semantic segmentation, focusing on pixel-level
361 recognition of ice-covered and background areas in transmission line images. Based on the raw icing images, this
362 study manually selects high-quality images with clearly distinguishable ice-covered regions. Subsequently, the Im-
363 ageLabeler tool in Matlab is used to label the ice-covered areas pixel by pixel, ensuring that each pixel's category label
364 accurately corresponds to either the ice-covered region or the background. Meanwhile, considering the fixed shooting
365 angle characteristics of the ice-viewing device, the ice-covered images underwent appropriate preprocessing and crop-
366 ping. To enhance data volume and enrich sample distribution, random flipping was applied. Ultimately, an ice-covered
367 region segmentation dataset, IceSeg, containing 6,360 pixel-level annotations, was constructed and split into training,
368 test, and validation sets in a 7:2:1 ratio.

Answer to
reviewer 1.
Comments 6:

3.3 Ice Type Identification Experiment

3.3.1 ResSepNet Branch Ablation Experiment

In ResSepNet, the ice type recognition task is achieved through the collaborative efforts of the background branch, icing branch, and global branch. The background branch preprocesses the original image to extract the background subgraph, focusing on capturing environmental features in the image while minimizing the interference of background noise. The icing branch, on the other hand, specializes in extracting features of the icing on the transmission line. It uses a structure similar to that of the background branch but places greater emphasis on capturing the details and texture information of the icing area. The global branch directly inputs the entire image, utilizing EfficientNet-B3 as the backbone network to extract macro features from the full image and capture global context information through a transfer learning model. The design of these three branches aims to capture both local and global information at different spatial scales by performing feature extraction in different regions, thereby effectively reducing the influence of background noise and improving the accuracy of ice type recognition. By normalizing and fusing the features extracted from the different branches, ResSepNet can fully leverage the spatial scale information extracted by each branch, ultimately leading to more accurate ice type recognition results.

Answer to reviewer 2. Comments 1:

To evaluate the performance of each branch in ResSepNet, this study conducts a controlled experiment comparing ResSepNet with its individual branches on the IceType dataset. The accuracy and loss variation curves of ResSepNet and its branches on the IceType validation set are illustrated in Fig. 8.

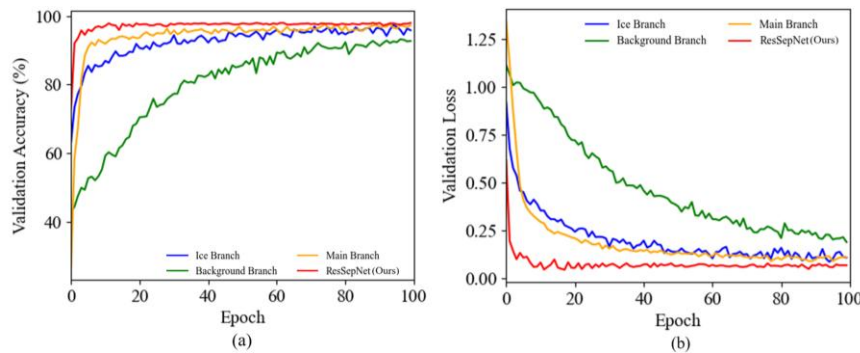

386
387 **Figure 8.** (a) validation accuracy and (b) validation loss. Performance of each branch of ResSepNet.

388
389 As shown in Fig. 8, the background branch alone yields suboptimal ice type recognition performance, achieving an
390 accuracy of only 86.55 %. The ice branch improves recognition accuracy to 89.82 %; however, it remains insufficient
391 due to the omission of environmental factors. ResSepNet, which integrates the background branch, icing branch, and
392 global branch, comprehensively accounts for both environmental influences and transmission line icing characteristics,
393 ultimately achieving a recognition accuracy of 95.23 %.

394 To more clearly illustrate the performance contribution of each branch across different ice types, the confusion
395 matrix for ice type recognition on the IceType test set is presented in Fig. 9.

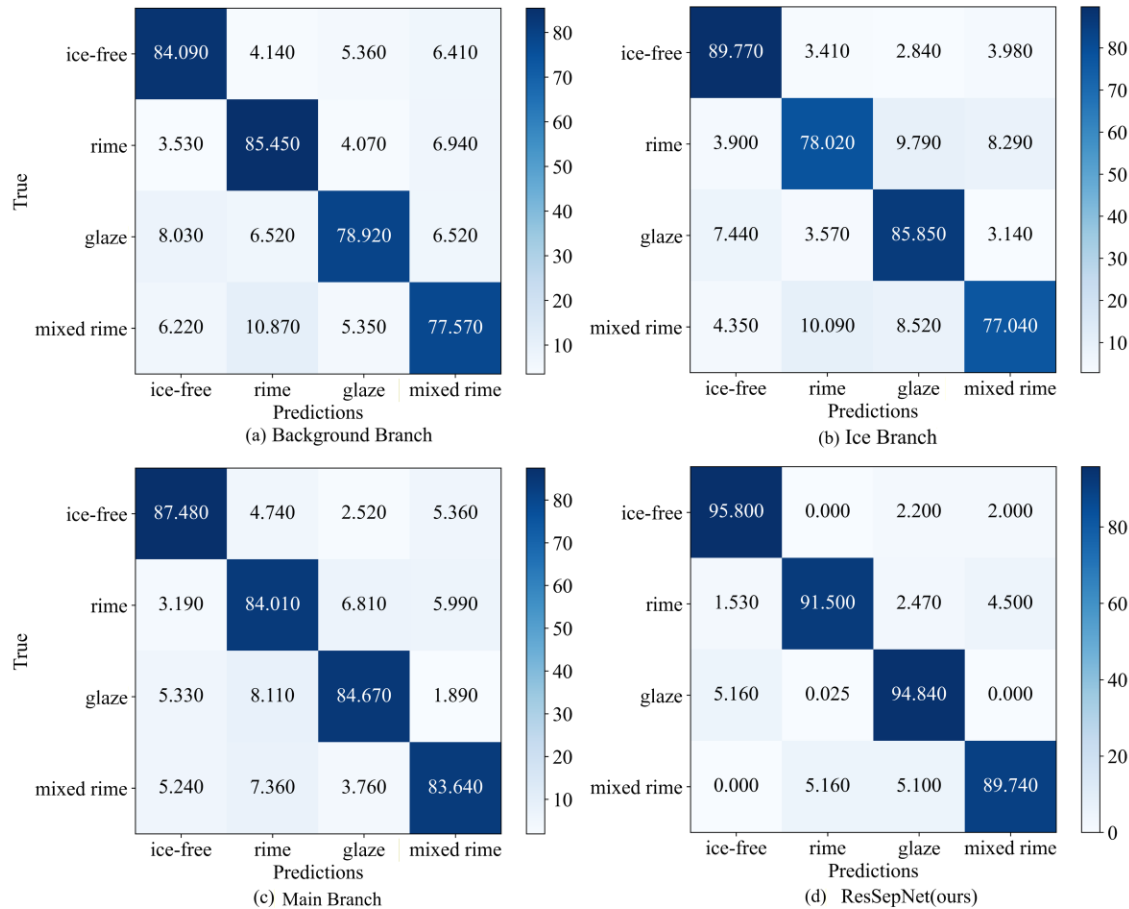

Figure 9. Confusion matrix of ice type recognition effect of each branch of ResSepNet.

396
397

398

399

400

401

402

403

404

405

406

407

408

409

410

411

412

413

414

For the results in Figure 9, five independent experimental runs were conducted and the average values were reported to ensure data stability and reliability. All runs used the same training and test datasets and were performed under identical hardware conditions to guarantee consistency. Thus, the confusion matrix in Figure 9 represents the averaged results with minimal variation, indicating high model stability across repeated experiments. Based on the confusion

matrix, it can be observed that the recognition accuracy of each branch and ResSepNet for mixed rime is lower compared to other ice types. This is attributed to the complex morphology of mixed rime. Nevertheless, ResSepNet still achieves a high recognition accuracy of 89.74 % for this type. This is because ResSepNet simultaneously extracts multi-scale features from the background area, ice-covered area, and the entire image, enabling a more comprehensive capture of image information. The background branch demonstrates superior rime recognition compared to other branches due to the distinct color differentiation of this type. The icing branch excels in recognizing bare wire (ice-free) since the morphology of the wire in this category exhibits more significant differences. The global branch maintains a more balanced recognition across various types, as it does not specifically extract local area features. This also compensates for the limitations of the background branch and icing branch in recognizing mixed rime and other complex types. Overall, ResSepNet achieves outstanding performance in ice type recognition, attaining high accuracy, which confirms that the multi-branch design is well-structured and significantly enhances the recognition capability for ice-covered types.

415 **3.3.2 Comparative Experiments with ResSepNet**

416 To evaluate the ice coating recognition performance of ResSepNet, comparative experiments were conducted on the
417 IceType dataset using mainstream models such as EfficientNet-V2 (Tan & Le, 2021), MobileNet-V3 (Howard et al.,
418 2019), ResNeXt (Xie et al., 2017), and MobileOne (Vasu et al., 2023). The accuracy and loss curves for each model
419 on the IceType validation set are presented in Fig. 10.

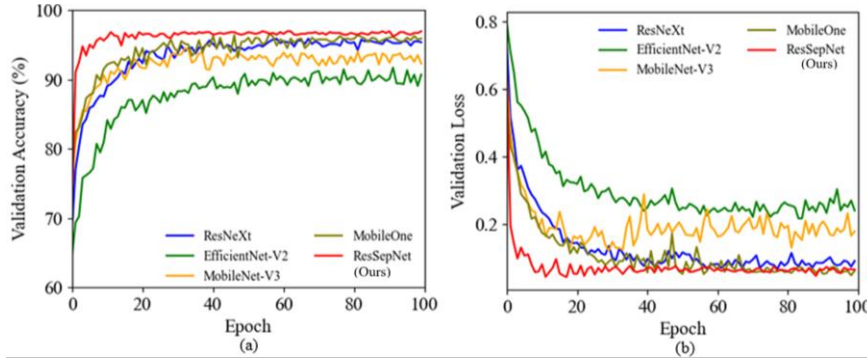

420 **Figure 10.** (a) validation accuracy and (b) validation loss. Performance comparison of various models.
421

422 As shown in Fig. 10, the ResSepNet model proposed in this paper not only achieves the highest accuracy but also
423 demonstrates superior convergence speed and stability. This performance can be attributed to the model's lightweight
424 and multi-branch structure, which allows it to maintain a compact size while ensuring rapid convergence. Additionally,
425 the multi-branch design enables more comprehensive capture of the ice coverage information, reduces the impact of
426 background noise, and enhances the overall recognition accuracy. The following section presents a comparison of
427 various evaluation metrics for each model on the IceType test set, as shown in Fig. 11.
428

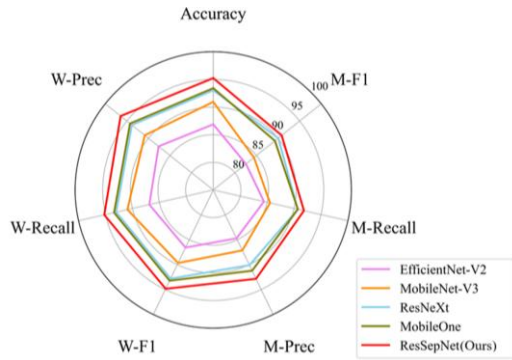

429 **Figure 11.** Comparison of evaluation indicators of various models.
430

431 From the radar chart comparison results in Fig. 11, it is evident that the proposed ResSepNet outperforms other models
432 in terms of accuracy, precision, recall, and F1-score. Compared with other methods, the proposed method achieves an
433 average improvement of 4.17 % in accuracy, 4.79 % in weighted precision (W-Prec), 4.17 % in weighted recall (W-
434 Recall), and 4.28 % in weighted F1-score (W-F1). Additionally, macro precision (M-Prec), macro recall (M-Recall),
435 and macro F1-score (M-F1) exhibit average improvements of 4.55 %, 4 %, and 4.26 %, respectively. Combined with
436 the results in Fig. 10, these findings demonstrate that ResSepNet consistently maintains superior performance in ice
437

438 type recognition, both in terms of individual evaluation metrics and overall effectiveness. The specific values corre-
 439 sponding to Figs. 10 and 11 are presented in Table 1, where the bolded values indicate the best results.

440 **Table 1. Comparison of icing type recognition performance of various recognition models**

Modules	Accuracy(%)	W-Prec(%)	W-Recall(%)	W-F1	M-Prec(%)	M-Recall(%)	M-F1
EfficientNet-V2	86.87	87.65	86.87	86.57	84.71	84.41	82.57
MobileNet-V3	90.93	90.86	90.93	89.67	87.13	85.55	84.42
ResNeXt	93.02	93.83	93.02	92.80	90.10	90.69	90.05
MobileOne	93.41	94.26	93.41	93.21	91.21	90.71	89.27
ResSepNet(Ours)	95.23	96.44	95.23	94.84	92.84	91.84	90.84

Answer to reviewer 1.
 Comments 6:

441 3.4 Icing Region Segmentation Experiment

442 3.4.1 Segmentation Effects in Different Scenarios

443 Since the accuracy of ice thickness calculation is directly influenced by the segmentation results of the icing region,
 444 this study evaluates the performance of the proposed icing region area segmentation module under various environ-
 445 mental conditions. To this end, segmentation tests were conducted in representative scenarios, including sunny days,
 446 heavy fog, and nighttime. The results are presented in Fig. 12, where the red regions indicate the segmentation results
 447 for the main view line, while the yellow regions represent those for the side view line.

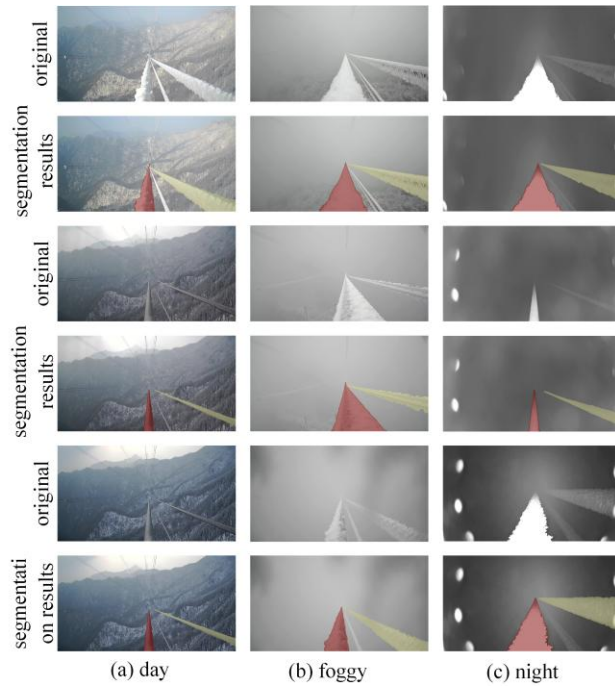

448 (a) day (b) foggy (c) night
 449 **Figure 12.** Icing region segmentation results of MOMSA-SegNet in different scenarios.
 450

451 As illustrated in Fig. 12, the proposed icing region segmentation module, MOMSA-SegNet, effectively segments both
 452 the main view line and the side view line across different environmental conditions, including sunny days, foggy
 453 conditions, and nighttime. These results demonstrate that the proposed segmentation method can reliably meet the
 454 requirements for ice thickness calculation.

3.4.2 Comparison of Segmentation Performance of Different Models

To further evaluate the segmentation performance of the proposed MOMSA-SegNet, classic models such as UNet++ (Zhou et al., 2018), SegNet (Badrinarayanan et al., 2017), and DySample (Lin et al., 2017) were trained on the IceSeg dataset and compared with MOMSA-SegNet on the test set. The evaluation primarily focused on key metrics, including the Intersection over Union (IoU) for the main view, side view, and background, as well as the mean IoU (MIoU) and mean Pixel Accuracy (mPA). The comparative results are presented in Table 2.

Table 2. Comparison of segmentation performance of different models

Modules	main view IoU (%)	Side view IoU (%)	background IoU (%)	MIoU	mPA
UNet++	86.12	70.97	98.73	85.27	64.85
SegNet	84.43	75.22	98.79	86.15	65.80
DySample	85.25	76.63	98.89	87.83	66.63
MOMSA-SegNet(Ours)	86.17	79.05	98.96	88.06	67.17

From Table 2, it can be observed that although the performance differences among the models are relatively small, MOMSA-SegNet achieves the highest scores across all evaluation metrics. Specifically, compared to other models, the proposed method improves the IoU of the main view and side view by 0.9 % and 4.78 %, respectively. Additionally, it enhances background IoU by 0.16 %, while MIoU and mPA increase by 1.64 % and 1.41 %, respectively. These results highlight the superior segmentation performance of MOMSA-SegNet across different scenarios. The comparative segmentation results of each model on the IceSeg test set are illustrated in Fig. 13.

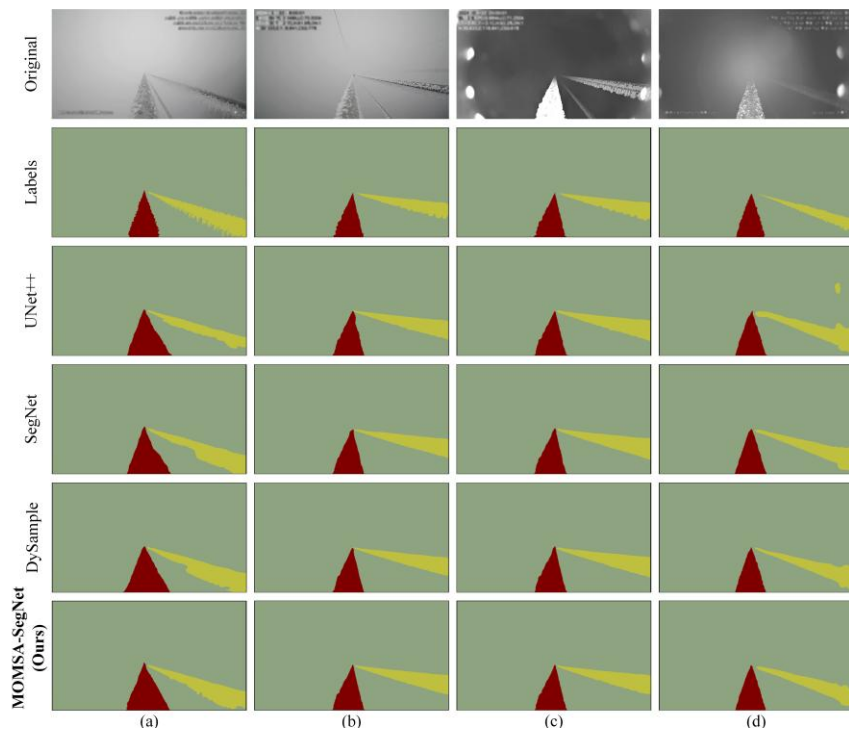

Figure 13. Comparison of segmentation performance across different models. (a) Segmentation result under daytime conditions (first image), (b) Segmentation result under daytime conditions (second image), (c) Segmentation result under nighttime conditions (first image), and (d) Segmentation result under nighttime conditions (second image).

Answer to reviewer 1. Comments 6:

474 Figure 13 intuitively demonstrates that the segmentation performance of each model on the main view line exhibits
475 minimal differences. However, under the influence of factors such as fog and ambient light, the segmentation results
476 for the side view line vary significantly among models. Notably, the proposed MOMSA-SegNet achieves superior
477 segmentation performance on the side view line and demonstrates the best overall performance. This can be attributed
478 to its jump connection structure and multi-scale attention mechanism, which effectively capture the characteristics of
479 different view lines and provide precise support for subsequent ice thickness calculations.

480 3.5 Ice Thickness Detection Experiment

481 3.5.1 Overall Thickness Detection Performance of the Observation Field

482 To verify the accuracy of the final ice thickness measurement, a simple pole tower and conductor device were con-
483 structed at the experimental site of Nanjing University of Information Science and Technology. This setup simulated
484 the actual ice conditions of the transmission line in a natural environment. Using an ice viewing device, a small trans-
485 mission line ice thickness dataset was created, covering ice thickness levels ranging from 0 to 30 mm, with a bare wire
486 diameter of 33.8 mm. To approximate the shooting angle of real ice monitoring equipment, pixel expansion processing
487 was applied to the original images, followed by annotation of the ice-covered areas. The results are shown in Fig. 14.
488 Due to site conditions, no side view line was included. The performance of the proposed model was validated using
489 the thickness dataset.

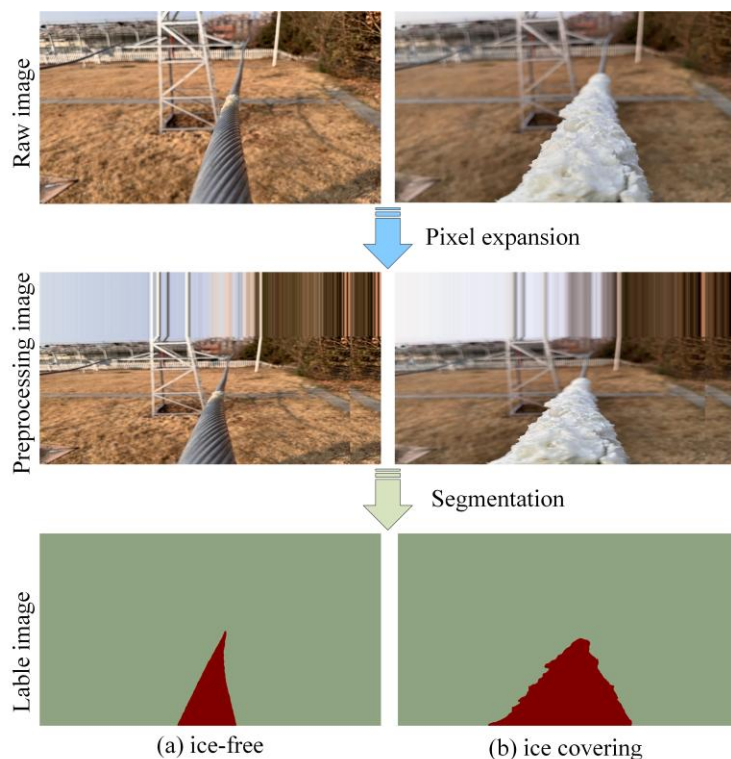

490 **Figure 14.** The segmentation effect of the ice-covered image of the simulated transmission line at the experimental site.
491

492

493 Based on the ice data collected from the observation field, we tracked the complete ice accumulation and variation
 494 process of the transmission line over a 24-hour period. The ice thickness measurement results for this process are
 495 illustrated in Fig. 15, with detailed values presented in Table 3. In the figure, dark blue represents the actual ice
 496 thickness, light blue denotes the optimized ice thickness estimated by the proposed model, and green indicates the
 497 initial ice thickness of the main (side) view line measured by the model. Given that the simulated ice cross-section is
 498 circular, the side view thickness is assumed to be equal to the main view thickness.

499 As shown in Fig. 15, both the initial and optimized thickness values align with the overall trend of the actual thick-
 500 ness, demonstrating that the proposed model can accurately capture the growth pattern of ice thickness. Moreover, the
 501 optimized thickness measurement is closer to the actual thickness, indicating that key meteorological data effectively
 502 refine the ice thickness estimation, yielding more accurate measurement results. To further evaluate the accuracy of
 503 the proposed method in detecting ice thickness, we compared the optimized and initial ice thickness measurements
 504 with the actual values. Additionally, we calculated key evaluation metrics, including the mean absolute percentage
 505 error (MAPE), Pearson correlation coefficient (PCC), and mean square error (MSE). The results are presented in Table
 506 4.

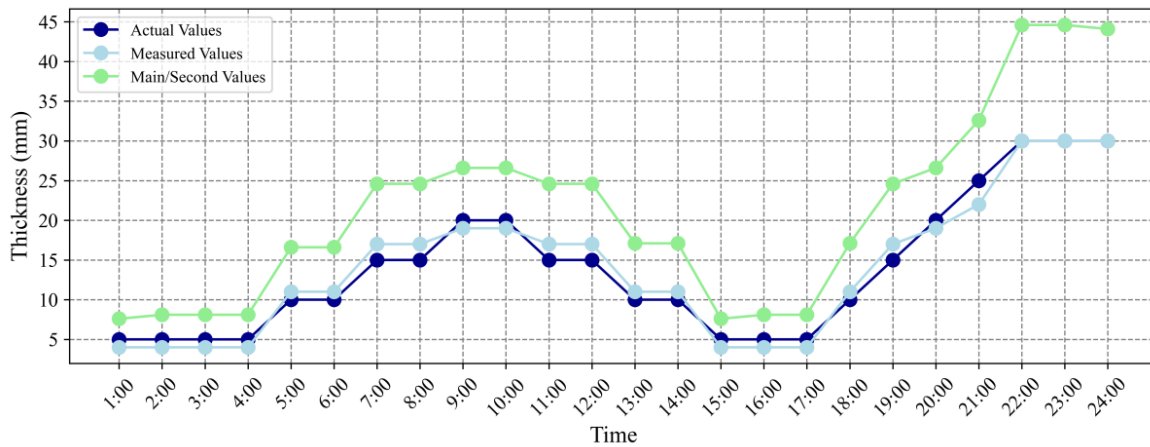

507
 508 **Figure 15.** Comparison curve between measured value and actual value.

509 **Table 3.** Comparison between measured values and actual values.

Time	1:00	2:00	3:00	4:00	5:00	6:00	7:00	8:00	9:00	10:00	11:00	12:00
Actual thickness (mm)	5	5	5	5	10	10	15	15	20	20	15	15
Initial thickness (mm)	7.6	8.1	8.1	8.1	16.6	16.6	24.6	24.6	26.6	26.6	24.6	24.6
Optimized thickness (mm)	4	4	4	4	11	11	17	17	19	19	17	17
Time	13:00	14:00	15:00	16:00	17:00	18:00	19:00	20:00	21:00	22:00	23:00	24:00
Actual thickness (mm)	10	10	5	5	5	10	15	20	25	30	30	30
Initial thickness (mm)	17.1	17.1	7.6	8.1	8.1	17.1	24.6	26.6	32.6	44.6	44.6	44.1
Optimized thickness (mm)	11	11	4	4	4	11	17	19	22	30	30	30

510 Note. The two lines of time represent the 12 hours before and after a day.
 511

512 **Table 4.** Evaluation index of ice thickness measurement value.

Evaluation index	MAPE(%)	PCC	MSE
Initial ice thickness	56.36	0.97	65.60
Optimized ice thickness	11.82	0.99	1.83

513
 514 As observed in Fig. 15 and Table 4, the optimized ice thickness calculated by the proposed model closely follows the
 515 actual values. The Pearson correlation coefficient reaches 0.99, indicating a strong correlation, while the measurement
 516 error remains minimal. The mean absolute percentage error is only 11.82 %, and the mean square error is as low as
 517 1.83, demonstrating the model's high accuracy. These results confirm that the proposed method performs well in real-
 518 world scenarios and meets the practical application requirements.

519 **3.5.2 Effect of Different Segmentation Models on Ice Thickness Detection**

520 To quantitatively evaluate the impact of the segmentation module on the accuracy of final ice thickness estimation,
 521 this study, under the premise of maintaining consistency in the ice type recognition and thickness optimization calcu-
 522 lation processes, uses UNet++, SegNet, DySample, and MOMSA-SegNet as the frontend segmentation models. The
 523 thickness estimation experiments were conducted on the same observation field test dataset. The ice type recognition
 524 module and thickness optimization calculation module were kept unchanged, and only the ice segmentation submod-
 525 ule was replaced with different typical methods. The initial thickness and optimized thickness errors were then com-
 526 puted on the corresponding observation field thickness test data. This approach allows a direct comparison of the
 527 effects of different segmentation models on geometric scale calculation and error propagation within a unified frame-
 528 work, providing a clearer insight into the structural relationship between segmentation quality and thickness detection
 529 accuracy. The experimental results are shown in Table 5.

530 **Table 5.** Comparison of ice thickness detection performance driven by different segmentation models

Modules	Initial ice thickness MAPE(%)	Optimized ice thick- ness MAPE(%)	Initial ice thickness MSE	Optimized ice thickness MSE
UNet++	69.53	14.58	80.93	2.26
SegNet	65.38	13.71	76.09	2.12
DySample	57.45	12.05	66.86	1.87
MOMSA-SegNet(Ours)	56.36	11.82	65.60	1.83

531
 532 As seen in Table 5, under the same ice type recognition and meteorological correction processes, the performance of
 533 ice thickness detection shows a consistent trend with different segmentation models as frontend submodules. The
 534 better the segmentation performance, the lower the initial and optimized thickness errors. When MOMSA-SegNet,
 535 the segmentation model proposed in this paper, is used, both the MAPE and MSE of the initial thickness are the lowest.
 536 After replacing it with UNet++, SegNet, or DySample, both errors increase to varying degrees. This indicates that the
 537 segmentation stage directly affects the accuracy of the ice contour and area depiction, which in turn influences the
 538 downstream geometric parameter estimation. Segmentation errors accumulate and amplify in the calculation of equiv-
 539 alent ice thickness.

Answer to
 reviewer 1.
 Comments 2:

Answer to
 reviewer 2.
 Comments 2:

540 A further comparison of the initial and optimized thickness metrics reveals that after the introduction of meteorological correction, the MAPE and MSE for all models significantly decrease, showing that the environmental-driven
541 correction terms can effectively compensate for the system errors caused by the 2D perspective and geometric simplifications. However, the relative differences between the models still remain even after optimization. Even with meteorological correction, the thickness estimation based on MOMSA-SegNet maintains the lowest MAPE and MSE,
542 while segmentation models with weaker performance still exhibit higher optimization errors. This suggests that the meteorological correction mainly targets global system biases related to environmental processes, and cannot fully
543 counteract the structural errors in the ice region contour and scale caused by segmentation. Thus, it can be concluded that segmentation quality determines the geometric baseline for thickness estimation, while meteorological correction
544 fine-tunes this baseline, forming a hierarchical complementary relationship.

545 In conclusion, under the condition of complete consistency in the thickness estimation algorithm and test dataset,
546 simply replacing the segmentation module results in a monotonous or nearly monotonous decrease in thickness errors with the improvement of segmentation model performance. This result confirms the substantial contribution of
547 MOMSA-SegNet in ice thickness detection from a data-driven perspective. Its higher segmentation accuracy not only reflects in pixel-level metrics but also significantly reduces the initial errors in downstream thickness estimation,
548 maintaining its advantage even after meteorological correction and effectively transmitting the improved segmentation performance to the final physical quantity estimation results.

Answer to
reviewer 1.
Comments 2:

557 3.5.3 Ablation Experiment on Multi-Source Input Data

558 To systematically assess the independent contributions and complementary relationship between image geometric information and meteorological factors in ice thickness estimation, this study conducted an ablation experiment based
559 on the observation field thickness test data. Under the premise of maintaining consistent datasets, thickness calibration methods, and evaluation metrics, three different information configurations were constructed. The first configuration
560 retained only the thickness estimation derived from the segmentation results and area ratio geometric relationship, aiming to measure the independent capability of the image geometric path; the second configuration relied solely on
561 meteorological features such as temperature, humidity, wind speed, and precipitation to directly fit ice thickness using a regression model, evaluating the prediction potential of environmental driving factors without image data; the third
562 configuration introduced the meteorological correction term based on geometric thickness, which is the complete fusion mode of DTL-IceNet proposed in this paper, used to test the practical benefits of the synergistic effects between
563 the two information sources. The comparison results of the three configurations are shown in Table 6.

564 **Table 6.** Comparison of ablation experimental results based on source input data

Model Configuration	Image geometry	meteorological elements	MAPE(%)	PCC	MSE
Image-only	Yes	No	58.51	0.96	69.70
Meteo-only	No	Yes	39.88	0.90	30.26
DTL-IceNet(Ours)	Yes	Yes	13.16	0.98	2.54

570 As seen in Table 6, the three input configurations exhibit clear hierarchical differences in thickness estimation accuracy, reflecting the complementary nature of image geometry and meteorological factors in terms of information

Answer to
reviewer 1.
Comments 5:

573 structure. In the Image-only mode, the PCC reaches 0.96, indicating that the geometric thickness derived from the
574 segmentation results and area ratio relationship can well capture the trend of ice variation over time. However, due to
575 the scale uncertainty introduced by single-view imaging, the amplification effect of segmentation errors on area esti-
576 mation, and the simplification of cross-sectional morphology, the magnitude deviation is still significant, with MAPE
577 reaching 58.51% and MSE reaching 69.70, which reflects the inherent limitations of the geometric path in the absence
578 of environmental process constraints. In the Meteo-only mode, the thickness estimation, relying on the phase changes
579 of meteorological conditions, partially captures the growth and melting rhythm of the ice layer, so the PCC remains
580 at a reasonable level of 0.90. However, due to the lack of spatial volume information, this mode struggles to differen-
581 tiate between absolute thickness differences, exhibiting characteristics of large magnitude errors and significant fluc-
582 tuations. These results indicate that meteorological factors alone cannot provide precise thickness information, espe-
583 cially in scenarios with small-scale changes and significant spatial heterogeneity.

584 In contrast, DTL-IceNet uses geometric thickness as a spatial scale constraint and employs meteorological features
585 to fit the systemic offset driven by environmental factors, significantly suppressing errors in both trend and magnitude.
586 The fusion mode's MAPE decreases significantly to 13.16%, MSE reduces to 2.54, and PCC increases to 0.98. This
587 demonstrates that the structured information provided by the geometric path and the phased features captured by the
588 meteorological path are highly complementary in mechanism, with the former determining the spatial baseline for
589 estimation and the latter correcting the deviations caused by changes in meteorological conditions. As the ice for-
590 mation process involves both geometric morphological evolution and meteorological-driven characteristics, both types
591 of information are indispensable. Therefore, a single modality struggles to achieve high accuracy in thickness predic-
592 tion, while the fusion mode can fully leverage the advantages of both types of information, reflecting a dual enhance-
593 ment in robustness and physical consistency.

Answer to
reviewer 1.
Comments 5:

594 **4 Discussion**

595 The dual-task learning framework, DTL-IceNet, proposed in this study demonstrates high reliability in both ice type
596 recognition and thickness detection tasks. Its main contribution lies in the unified modeling of three types of infor-
597 mation: type, geometry, and meteorology, which effectively enhances the comprehensive sensing ability of icing con-
598 ditions on transmission lines. This fusion-based design aligns with the view emphasized in the literature that "ice
599 physics, image features, and environmental processes must be considered in a coordinated manner" (Fan et al., 2018;
600 Hao et al., 2023; Chen et al., 2024; Dong et al., 2022; Meng et al., 2025; Han et al., 2024), and it achieves both
601 discriminative ability and physical consistency in typical monitoring scenarios, leading to significant improvements
602 over existing methods.

603 In the ice type recognition task, the model explicitly separates the background, conductor, and icing regions through
604 a multi-branch feature extraction structure. Studies by Fan et al. (2018). and Hao et al. (2023) have pointed out that
605 ice recognition is highly sensitive to the environmental background, and deep networks based on a single-path feature
606 extraction often struggle to fully capture the local texture of the conductor in complex backgrounds. The decomposi-
607 tion-based modeling approach of DTL-IceNet significantly enhances the distinction between different types of icing

Answer to
reviewer 1.
Comments 1:
Answer to
reviewer 2.
Comments 2:

608 under complex lighting, fog, and noise conditions, providing stronger anti-interference ability compared to single-
609 branch methods.

610 In the ice region segmentation task, MOMSA-SegNet leverages a multi-scale attention module to improve the rep-
611 resentation capability of thin conductors and irregularly shaped icing areas. Existing research has shown that tradi-
612 tional edge detection or low-level feature methods exhibit poor robustness in weak boundaries, low contrast, and
613 nighttime scenarios (Han et al., 2024; Tan & Le, 2019; Hu et al., 2018; Vasu et al., 2023; Li et al., 2016). In contrast,
614 the multi-scale attention mechanism effectively utilizes the contextual structure surrounding the transmission line,
615 allowing the model to maintain stable geometric contour predictions in typical scenes such as sunny, foggy, and
616 nighttime conditions. Its accuracy advantage stems from the targeted utilization of the transmission line image struc-
617 ture rather than relying solely on the depth of the network or the scale of parameters.

618 For ice thickness estimation, the improvement in model performance is mainly attributed to the synergistic effect
619 of geometric and meteorological constraints. The image geometric information provides the basic trend of ice volume
620 changes, but relying solely on 2D images cannot accurately reflect the true 3D shape of the ice, leading to systematic
621 biases during temperature, humidity, wind speed, and precipitation phases. By introducing the meteorological correc-
622 tion term based on environmental factors, the model performs consistent corrections on the initial thickness estimation
623 according to the basic physical laws of ice growth and melting, effectively compensating for the inherent structural
624 biases in the geometric estimation. Experimental results show that the thickness curves align more closely with the
625 actual distribution across multiple phases, indicating the complementary role of geometric and meteorological infor-
626 mation in thickness estimation.

627 Although DTL-IceNet demonstrates robustness under typical monitoring conditions, its applicability is still limited
628 by the data coverage and experimental conditions. The data used in this study were primarily collected in typical
629 meteorological scenarios and have not yet covered extreme weather conditions such as severe convection or freezing
630 rain coupled with strong winds. Under such conditions, the signal-to-noise ratio of images and the rate of ice mor-
631 phology change may exceed the training distribution, and the model's robustness needs further validation. Moreover,
632 the current experimental data do not systematically reflect complex spatial environments with significant topographic
633 variations. Existing studies have shown that terrain, especially in valley wind fields, significantly impacts icing dis-
634 tribution, so the model's performance in complex terrain scenarios remains uncertain.

635 While the segmentation experiments presented in this study systematically show performance differences under
636 various imaging conditions such as sunny days, fog, and nighttime, the thickness validation experiments were limited
637 by the actual conditions of the observation field, which only included real thickness calibration data from sunny sce-
638 narios and could not directly quantify thickness estimation accuracy under various weather conditions. To address this
639 logical gap, we will further analyze the potential impact of weather factors on thickness estimation. Mechanistically,
640 weather changes affect thickness results mainly through two paths. First, imaging degradation such as fog and low
641 light reduces the clarity of the ice and conductor boundaries, causing segmentation masks to deviate in geometric
642 details and directly affecting the preliminary thickness calculation based on area and contour inference. Second, me-
643 teorological variables such as temperature, humidity, and wind speed determine the growth and melting rates of the
644 ice, strongly driving the temporal evolution of thickness. The meteorological correction module of DTL-IceNet can

645 provide systematic corrections based on this driving pattern, but it cannot completely compensate for geometric devi-
646 ations caused by severe imaging degradation. Therefore, under real fog or nighttime conditions, the initial thickness
647 errors may increase, while the optimized thickness is expected to show more stable but still limited corrections.

Answer to
reviewer 1.
Comments 3:

648 The dual-perspective approach proposed in this study is one of the key innovations of the overall framework.
649 Through joint segmentation of the main and side perspectives, the major and minor axes of the ice-covered cross-
650 section can be theoretically estimated, improving the certainty of geometric parameters. However, it is important to
651 note that the thickness validation experiment in this paper was limited by site constraints and did not actually deploy
652 transmission lines for real side-perspective imaging. Thickness detection relied on a simplified geometric assumption
653 primarily based on the main perspective. This experimental condition means that the final obtained thickness accuracy
654 mainly reflects the performance under the simplified single-perspective system rather than the upper limit of a com-
655 plete dual-perspective structure. Therefore, while the current results prove the feasibility and potential value of the
656 proposed framework, they do not fully validate the information gain of the dual-perspective structure in real multi-
657 conductor scenarios. This also suggests that the side-perspective segmentation error's impact on thickness calculation
658 has not been fully quantified. Future work will focus on building an experimental platform that truly reflects the dual-
659 perspective structure to systematically evaluate error propagation mechanisms and further optimize geometric fusion
660 methods.

Answer to
reviewer 1.
Comments 4:

661 In summary, DTL-IceNet forms a cohesive solution across ice type recognition, geometric structure extraction, and
662 thickness estimation, with its advantages derived from complementary constraints between tasks and explicit incor-
663 poration of physical processes.

664 **5 Summarize**

665 To address the challenge of insufficient accuracy in ice coating recognition and thickness detection for high-altitude
666 transmission lines, this paper proposes DTL-IceNet, dual-task learning architecture with multi-scale fusion mecha-
667 nisms for enhanced ice detection on transmission lines, which enables precise ice coating recognition and ice thickness
668 estimation. The proposed method employs ResSepNet, a multi-branch network designed to fuse and extract ice features
669 across different spatial scales, effectively mitigating background noise interference and enhancing ice type classifica-
670 tion accuracy. Additionally, a semantic segmentation network, MOMSA-SegNet, incorporating a skip structure and
671 multi-scale attention mechanism, is utilized to segment icing regions on transmission lines, thereby facilitating ice
672 thickness estimation. Furthermore, key meteorological data are integrated to optimize the correction of ice thickness
673 measurements. Based on the original ice images provided by the power grid, we constructed a series of ice image
674 datasets, including IceType and IceSeg. The experimental results demonstrate that the proposed DTL-IceNet achieves
675 4.17 % higher ice recognition accuracy compared to EfficientNet-V2, MobileNet-V3, ResNeXt, and MobileOne,
676 while its ice area segmentation MIoU surpasses that of mainstream segmentation models such as UNet++ by 1.64 %.
677 These findings indicate that the dual-task learning framework effectively detects and identifies both ice type and
678 thickness on transmission lines. Furthermore, in the simulation test at the test site, the MAPE of ice thickness estima-
679 tion reached 11.82 %, and the PCC attained 0.99, demonstrating the proposed method's robust ice detection perfor-
680 mance in real-world conditions. However, due to hardware limitations, this study does not account for the impact of

681 terrain elements on transmission line icing. The detection performance of the proposed method under significant en-
682 vironmental changes requires further improvement. Future work will focus on incorporating terrain elements into the
683 model and examining their correlation with transmission line icing.

684 **Data Availability Statement**

685 The datasets and code utilized for the analyses in this study are publicly available at [https://doi.org/10.5281/ze-](https://doi.org/10.5281/zenodo.15718305)
686 [nodo.15718305](https://doi.org/10.5281/zenodo.15718305) (Fu et al., 2025).

687 **Author contributions**

688 Yufei Fu, Wenjie Zhang planned the campaign; Yang Cheng, SongYuan Cao, Ling Tan performed the measure-
689 ments; Yufei Fu, Jiaxin He, Mengya Wang, Wenjie Zhang analyzed the data; Yufei Fu and Wenjie Zhang wrote the
690 manuscript draft; Wenjie Zhang, Yang Cheng, SongYuan Cao, reviewed and edited the manuscript.

691 **Competing interests**

692 The authors declare that they have no conflict of interest.

693 **Acknowledgments**

694 The authors declare no conflicts of interest. This work was supported by National Key R&D Program of China (Grant
695 No. 2023YFE0208100).

696 **References**

- 697 Ansari, S., Rennie, C. D., Clark, S.P., & Seidou, O.: River Ice Detection and Classification using Oblique Shore-bas
698 ed Photography, Cold Regions Science and Technology., 228, 104303, [https://doi.org/10.1016/j.coldregions.2024.10](https://doi.org/10.1016/j.coldregions.2024.104303)
699 [4303](https://doi.org/10.1016/j.coldregions.2024.104303), 2024.
- 700 Badrinarayanan, V., Kendall, A., & Cipolla, R.: Segnet: A deep convolutional encoder-decoder architecture for imag
701 e segmentation, IEEE transactions on pattern analysis and machine intelligence., 39(12), 2481-2495, [https://doi.org/1](https://doi.org/10.1109/TPAMI.2016.2644615)
702 [0.1109/TPAMI.2016.2644615](https://doi.org/10.1109/TPAMI.2016.2644615), 2017.
- 703 Chen, J. B., Yang, R., Wang, Q., Chai, J., Zhang, G. R., & He, Y. C.: Icing Detection of Transmission Lines Based o
704 n Improved YOLOv8, Measurement and Control Technology., 43(11), 23-30, [https://doi.org/10.19708/j.ckjs.2024.0](https://doi.org/10.19708/j.ckjs.2024.04.220)
705 [4.220](https://doi.org/10.19708/j.ckjs.2024.04.220), 2024.
- 706 Chen, Q., Liu, T., Wang, Z., & Miao, R.: Research on monitoring method for ice-covered state of transmission lines
707 based on conductor end displacement, Electric Power Systems Research., 236, 110918, [https://doi.org/10.1016/j.eps](https://doi.org/10.1016/j.epsr.2024.110918)
708 [r.2024.110918](https://doi.org/10.1016/j.epsr.2024.110918), 2024.
- 709 Dong, B. B., Jiang, X. L., & Xiang, Z.: Calculation model and experimental verification of equivalent ice thickness o
710 n overhead lines with tangent tower considering ice and wind loads, Cold Regions Science and Technology., 200, 10
711 3588, <https://doi.org/10.1016/j.coldregions.2022.103588>, 2020.

712 Fan, C. J., & Jiang, X.: Analysis of the icing accretion performance of conductors and its normalized characterizatio
713 n method of icing degree for various ice types in natural environments, *Energies*, 11(10)., 2678, <https://doi.org/10.33>
714 [90/en11102678](https://doi.org/10.3390/en11102678), 2018.

715 Fu, Y., Cheng, Y., Cao, S., Tan, L., He, J., Wang, M., Zhang, W., & Yang, Y.: Data from the article "DTL-IceNet: A
716 Dual-Task Learning Architecture with Multi-Scale Fusion Mechanisms for Enhanced Ice Detection on Transmissio
717 n Lines" [Data set], Zenodo, <https://doi.org/10.5281/zenodo.15718305>, 2025.

718 Gui, Q. X., Wang, G., Wang, L., Cheng, J., & Fang, H.: Road surface state recognition using deep convolution netw
719 ork on the low-power-consumption embedded device, *Microprocessors and Microsystems.*, 96, 104740, <https://doi.o>
720 [rg/10.1016/j.micpro.2022.104740](https://doi.org/10.1016/j.micpro.2022.104740), 2023.

721 Han, S., Li, D., Li, K., Wu, H., Gao, Y., Zhang, Y., & Yuan, R.: Analysis and study of transmission line icing based
722 on grey correlation Pearson combinatorial optimization support vector machine, *Measurement.*, 236, 115086, <https://>
723 doi.org/10.1016/j.measurement.2024.115086, 2024.

724 Han, X. B., Wang, J., Sun, P., Xing, B., & Jiang, X. L.: Research on transmission line icing thickness detection base
725 d on adaptive switching median filter, *Journal of Chongqing University of Technology(Natural Science).*, 37(8), 265
726 -273, [https://doi.org/10.3969/j.issn.1674-8425\(z\).2023.08.030](https://doi.org/10.3969/j.issn.1674-8425(z).2023.08.030), 2023.

727 Hao, Y., Wang, X., Liang, W., Zhang, W. X., He, J. Q., Wang, J. X. & Wu, J. R.: Ice Types Identification and Predi
728 ction of Overhead Transmission Lines Driven by Micro-Meteorological Data of Three Consecutive Days Icing, *Sout
729 hern Power System Technology.*, 17(06), 107-116, <https://doi.org/10.13648/j.cnki.issn1674-0629.2023.06.013>, 2023.

730 He, J. Q., Li, R. H., Li H., Liao, Y. L., Gong, B., & Hao, Y. P. et al.: Visible Light Image Automatic Recognition an
731 d Segmentation Method for Overhead Power Line Insulators Based on Yolo v5 and Grabcut, *Southern Power System
732 Technology.*, 17(6), 128-135, <https://doi.org/10.13648/j.cnki.issn1674-0629.2023.06.015>, 2023.

733 He, J., Wang, Z. G., Cao, J. P., Chen, L., & Lian, Y. F.: Detection and Segmentation of Overhead Transmission Line
734 Icing Conductor Based on Improved YOLOv5, In *2023 3rd International Conference on New Energy and Power En
735 gineering (ICNEPE)*, <https://doi.org/10.1109/ICNEPE60694.2023.10429575>, 2023

736 He, X. Q., Wu, X. Y., & Wei, Y. W.: Measurement method for thickness of uneven icing on transmission line in com
737 plex background, *Journal of Electric Power Science and Technology.*, 38(03), 224-229, <https://doi.org/10.19781/j.iss>
738 [n.1673-9140.2023.03.025](https://doi.org/10.19781/j.issn.1673-9140.2023.03.025), 2023

739 Howard, A., Sandler, M., Chu, G., Chen, L. C., Chen, B., Tan, M., & Adam, H. et al.: Searching for mobilenetv3, In
740 *Proceedings of the IEEE/CVF international conference on computer vision.*, <https://doi.org/10.1109/ICCV.2019.001>
741 [40](https://doi.org/10.1109/ICCV.2019.00140), 2019.

742 Hu, J., Shen, L., & Sun, G.: Squeeze-and-excitation networks, In *Proceedings of the IEEE conference on computer v
743 ision and pattern recognition*, <https://doi.org/10.48550/arXiv.1709.01507>, 2018.

744 Kong, X. H., Guan, H. L., Jiang, L., Wang, Y. Y., & Zhang, C.: Icing detection on ADSS transmission optical fiber c
745 able based on improved YOLOv8 network, *Signal, Image and Video Processing.*, 18(6-7), 5323-5332, <https://doi.org>
746 [/10.1007/s11760-024-03235-9](https://doi.org/10.1007/s11760-024-03235-9), 2024.

747 L, Y. K.: Research on Icing identification of Transmission Lines Based on YOLO Optimized Edge Detection, (Master's thesis), Beijing: North China Electric Power University, <https://doi.org/10.27140/d.cnki.ghbbu.2024.001039>, 20
748 24.
749
750 Li, D. L., Cao, L., & Yang, X. D.: Discussion on Otherness of the Calculated Methods for Conductor Icing Density in
751 Transmission Line, *Electric Power Survey & Design.*, 28(2), 177-179, <https://doi.org/10.13500/j.cnki.11-4908/tk.2016.s2.041>, 2016.
752
753 Lin, G., Milan, A., Shen, C., & Reid, I.: Refinenet: Multi-path refinement networks for high-resolution semantic seg-
754 mentation. In Proceedings of the IEEE conference on computer vision and pattern recognition, <https://doi.org/10.48550/arXiv.1611.06612>, 2017.
755
756 Liu, W. X., Tsamados, M., Petty, A., Jin, T. Y., Chen, W.B., & Stroeve, J.: Enhanced sea ice classification for ICES
757 at-2 using combined unsupervised and supervised machine learning, *Remote Sensing of Environment.*, 318, 114607,
758 <https://doi.org/10.1016/j.rse.2025.114607>, 2025.
759
760 Liu, X. Y., Peng, H. W., Zheng, N. X., Yang, Y. Q., Hu, H., & Yuan, Y. X.: EfficientViT: Memory Efficient Vision
761 Transformer with Cascaded Group Attention, In proceedings of the IEEE/CVF conference on computer vision and p-
762 attern recognition, <https://doi.org/10.48550/arXiv.2305.07027>, 2023.
763
764 Meng, X., Tian, L., Liu, J., & Jin, Q.: Failure prediction of overhead transmission lines incorporating time series pre-
765 diction model for wind-ice loads, *Reliability Engineering & System Safety.*, 259, 110927, <https://doi.org/10.1016/j.ress.2025.110927>, 2025.
766
767 Tan, M., & Le, Q.: Efficientnet: Rethinking model scaling for convolutional neural networks, In International confer-
768 ence on machine learning, <https://doi.org/10.48550/arXiv.1905.11946>, 2019.
769
770 Tan, M., & Le, Q. (2021). Efficientnetv2: Smaller models and faster training. In International conference on machine
771 learning. <https://doi.org/10.48550/arXiv.2104.00298>
772
773 Vasu, P. K. A., Gabriel, J., Zhu, J., Tuzel, O., & Ranjan, A.: Mobileone: An improved one millisecond mobile backb-
774 one, In Proceedings of the IEEE/CVF conference on computer vision and pattern recognition, <https://doi.org/10.48550/arXiv.2206.04040>, 2023.
775
776 Xie, S., Girshick, R., Dollár, P., Tu, Z., & He, K.: Aggregated residual transformations for deep neural networks, In
777 Proceedings of the IEEE conference on computer vision and pattern recognition, <https://doi.org/10.48550/arXiv.1611.05431>, 2017.
778
779 Xu, Q., Li, D., Peng, H., Li, C., Chen, H., & Dong, J.: Support Vector Machine-Based Impact Analysis of Multidime-
780 nsional Ice-Covering Factors, In 2023 3rd International Conference on New Energy and Power Engineering (ICNEPE), <https://doi.org/10.1109/ICNEPE60694.2023.10429504>, 2023.
781
782 Yang, J., Gao, Y. F., Zhang, K., Wang, Y., Zhang, Y. L., Xia, N., & Yao, G.: A Conductor Icing Monitoring Method
783 Based on Image Edge Detection and Normal Direction Detection, *Power System and Clean Energy.*, 39(02), 24-32,
784 <https://doi.org/10.3969/j.issn.1674-3814.2023.02.004>, 2023
785
786 Zhang, Y., Cheng Z., & Liu Y.: Research Progress and Development Trends on Online Icing-monitoring of Transmi-
787 ssion Lines, *Power Systems and Big Data.*, 27(06), 32-42, <https://doi.org/10.1049/enc2.12131>, 2024.

783 Zhou, Z., Rahman Siddiquee, M. M., Tajbakhsh, N., & Liang, J.: Unet++: A nested u-net architecture for medical im
784 age segmentation, In Deep learning in medical image analysis and multimodal learning for clinical decision support:
785 4th international workshop, https://doi.org/10.1007/978-3-030-00889-5_1, 2018.