

Simultaneous measurement of greenhouse gases (CH₄, CO₂ and N₂O) using a simplified gas chromatography system

Michał Bucha¹, Dominika Lewicka-Szczebak¹, Piotr Wójtowicz^{2,3}

5

¹ Institute of Geological Sciences, University of Wrocław, pl. M. Borna 9, 50-204 Wrocław, Poland

² Department of Environmental Engineering, West Pomeranian University of Technology, Piastów 45, 70-311 Szczecin, Poland

³ Shim-Pol A.M. Borzymowski, Official Shimadzu Distributor in Poland, ul. Kochanowskiego 49A, 01-864 Warszawa, Poland

10

Correspondence to: Michał Bucha (michal.bucha@uwr.edu.pl)

Abstract. This article presents a simple method for determining greenhouse gases (CH₄, CO₂, N₂O) using an alternative new set-up of the chromatographic system. The novelty of the presented method is the application of a Carboxen 1010 PLOT capillary column for separation of trace gases – CH₄, CO₂ and N₂O – from air samples and their detection using a barrier discharge ionisation detector (BID). Simultaneously, a parallel molecular sieve column RT-Msieve 5A connected to a thermal conductivity detector (TCD) allowed the determination of CH₄, N₂ and O₂ concentrations from 0.2 to 100 %. The system was equipped with an autosampler transferring the samples without air contamination thanks to a vacuum pump-inert gas flushing option. Method validation was performed using commercial gas standards and undertaking a comparison measurement with a reference method: optical methods applying Picarro isotope and concentration instruments with cavity ring-down spectroscopy for CO₂, CH₄ and N₂O. A three-day continuous measurement series of GHG concentrations in ambient air and tests of typical vial sample measurements with increased GHG concentrations were performed.

The advantage of this method is that the system is easy to set up and allows for simultaneous detection and analysis of the main GHGs using one GC column and one detector, thereby omitting the need for an electron capture detector (ECD) containing radiogenic components for N₂O analysis and a flame ionisation detector (FID) with a methaniser for low-concentration CO₂ samples. The simplification of the system reduces analytical costs, facilitates instrument maintenance and improves measurement robustness.

1 Introduction

30 The reduction of greenhouse gas (GHG) emissions caused by human activity presents a major challenge that needs to be addressed in order to limit the effects of global warming. The main GHGs responsible for global warming are CO₂, CH₄ and N₂O (Lamb et al., 2021). Besides natural sources (e.g. volcanic activity, peat bogs, paddy soils, fresh and saltwater sediments etc.), human activity also contributes to increasing GHG emissions by having an impact on global carbon and nitrogen cycling.

Therefore, precise measurement of GHG concentrations from natural sources and the environment is crucial in order to quantify and estimate the contribution of different anthropogenic sources to worldwide emissions. The development of analytical equipment in recent years has allowed the application of user-friendly methods to determine trace gases and monitor slight changes in their concentrations precisely, even at the lowest levels expressed in units ppm and/or ppb (Zaman et al., 2021). In the very near future, it can be expected that analytical devices and their measurement precision will be enhanced further. Therefore, in order to maintain reliable continuity of measurement data on GHG concentrations in the atmosphere and in other elements of the Earth's ecosystem, measurements should be performed with the utmost care using the most modern techniques and devices available. It is also important to maintain easy access to simple and relatively cheap analytical devices and their ease of use in order to obtain more statistical data. Often the analytical devices providing very precise measurements have limitations in the analytical range and do not allow for observations of GHGs in a wide range of concentrations observed in nature. Therefore, the development of a new analytical method that is characterized by relatively high sensitivity in the range from the lowest to the highest concentrations is a desirable feature, but quite difficult to achieve in a single device. Several methods are available for monitoring GHG based on optical techniques such as non-dispersive infrared spectroscopy (NDIR), Fourier-transform infrared spectroscopy (FTIR), photoacoustic spectroscopy (PAS), tunable laser absorption spectroscopy (TLAS), cavity ring-down spectroscopy (CRDS), and off-axis integrated cavity-output spectroscopy (OA-ICOS) (Zaman et al., 2021). Some of these laser instruments allow for simultaneous analyses of CH₄, CO₂, N₂O and NH₃ using the laser absorption spectroscopy method (e.g. Picarro G2509 Gas Concentration Analyzer). Although these devices guarantee the stability of continuous measurements, their measurement range is much lower than chromatographic systems equipped with typical detectors. For example, the Picarro G2509 operation range for CO₂ is 380-6000 ppm, for CH₄ 1-800 ppm and for N₂O 0.3-200 ppm. Other versions of Picarro analysers have been developed to measure single GHG concentrations, e.g. of CH₄, CO₂ or N₂O, in combination with analyses of stable isotope composition of carbon or nitrogen from atmospheric air or headspace samples (SSIM module). These methods are recommended only for the measurement of a single gas compound at very specific concentrations. Thus, the most reliable methods for GHGs measurements in a very wide range of concentrations are chromatographic methods (Ekeberg et al., 2004). Another important limitation of the laser-based system is the sample matrix, which should be stable and most similar to standard ambient air composition. Hence, these methods are not well suited for untypical gas samples, like e.g. mine gases, or samples originating from laboratory experiments, e.g. with He atmosphere. Gas chromatography with automated sampling injections is a very common, flexible and user friendly technique. The most common GHG measurement systems have been developed with: a thermal conductivity detector (TCD) (measurement of CH₄ and CO₂), flame ionisation detector - FID (measurement of CH₄ and CO₂ using a methaniser), electron capture detector - ECD (for N₂O measurement) (Hedley et al., 2006; Loftfield et al., 1997; Wang and Wang, 2003). The GC systems can be dedicated for specific gases at ambient concentrations with precision similar or even better to those achieved by optical techniques. Van der Laan et al. (2009) developed the GC system which allows for simultaneous measurement of CH₄, CO₂, N₂O, CO and SF₆ using one gas chromatograph and single injection, that allows the measurement of GHGs from ambient air at remote stations. However, the system is characterised by a quite complex set-up with multiple gas valves, columns, methaniser, ECD and FID.

The most popular analytical technique for determining N₂O concentration is gas chromatography equipped with ECD using Porapak Q or Hayesep Q columns (Rapson and Dacres, 2014). However, the use of an ECD is associated with additional difficulties. The main disadvantage of the ECD is its poor stability over a long period of time. During ongoing analyses, the cell interior may become contaminated and natural wear may occur. This can result in an increasing response to the tested concentrations. Consequently, within a week a significant increase in the measured area may be observed for the same analysed concentrations. This drift can be compensated for by the addition of an internal standard. Moreover, due to the presence of radioactive material in the ECD, special safety requirements have to be taken into account. According to current regulations, the purchase of a new unit, its possession and the disposal of a used detector cell involve a number of formal requirements.

In the case of the dielectric barrier discharge ionisation detector (BID), there are no such limitations and restrictions. The only requirement is to ensure a supply of helium of appropriate purity (99.9999 %). The detector is incredibly stable and maintenance-free for a very long period of time. Application of the BID for N₂O measurements has the advantages of avoiding radiogenic compounds present in the ECD and reducing the number of gases required. Combination of ECD+FID requires installation of minimum 3 gas tanks (carrier gas He, Ar, or N₂; synthetic air; H₂ or H₂ generator; make-up gas for ECD N₂ of 6.0 purity, min. 99.9999%), whereas for BID only He tank is required.

Separation of CH₄, CO₂, and N₂O from one sample can be done using, for example, a system of two columns with 10-port valves (Scion Instruments, 2023) or a single column e.g. Micropacked ST Shin Carbon or RT Q-Bond column (Shimbo and Uchiyama, 2022). Methods using a single-column Micropacked ST Shin Carbon or RT Q-Bond are typically applied by Shimadzu using a GC Nexis 2030 gas chromatograph equipped with a dielectric barrier discharge ionisation detector (BID) dedicated to trace compounds (Shimbo and Uchiyama, 2022). This set-up using single column and single BID detector is commonly used for determination of CH₄ and CO₂ at very low atmospheric concentrations (Gruca-Rokosz et al., 2020). Unfortunately, the retention times for CO₂ and N₂O are often insufficient for correct measurement, especially by high CO₂ concentrations, when CO₂ tailing can even cover the N₂O peak. This separation can be enhanced by application of cryogenic methods for decreasing oven temperature. However, these methods are time-consuming and expensive. The present study tested an alternative solution that involved the application of Carboxen 1010 PLOT for CH₄, CO₂ and N₂O separation.

A simple chromatographic system is presented here for quick and accurate analysis of GHG using TCD and BID of the GC Nexis 2030 gas chromatograph combined with an AS-210 Greenhouse Gas Autosampler (SRI Instruments Europe GmbH, Bad Honnef, Germany) at wide range of concentrations from ambient observed in the Earth's atmosphere to the higher fluxes observed typically for the measured emission sources.

The GC separation columns used in this study were performed with a porous layer open tubular column (Carboxen 1010 PLOT) and a molecular sieve column (RT-Msieve 5A), which assured the full separation of the analysed gases. The results of the experimental data were compared with the concentrations obtained for CH₄, CO₂ and N₂O using the CRDS technique by Picarro analysers (G2201-i for CO₂ and CH₄; G5131-i for N₂O).

100 2 Materials and methods

2.1 Gas chromatography system

This chromatographic system was built based on the Shimadzu GC Nexis 2030 equipped with two parallel detectors: BID and TCD (Fig. 1). The carrier gas was controlled by an advanced flow controller (AFC) connected to a split/splitless injector. Between the AFC and the injector, a two-position six-port valve with a 1 mL (or 2 mL) sample loop was placed on the carrier
105 line.

The gas chromatograph oven was equipped with an additional cryogenic option (CRG) where liquid nitrogen (LN₂) was used as a cooling agent, which allowed for separation at below-ambient temperatures. The samples from AS-210 Greenhouse Gas Autosampler (SRI Instruments GmbH) were transferred to the sampling valve through a stainless steel transfer line continuously warmed to 110°C with heating tape to prevent moisture contamination. The presence of moisture in the samples
110 results in loss of sorption capacity of carbon molecular sieves which are used commonly for separation of gases (Fastyn et al., 2003). The injection was performed by valve rotation. The sample was transferred from the loop (1 mL or 2 mL) through the injector at a total flow of 10 mL/min, and was then split 1:7 just before the column inlet. This was sufficient to achieve a good peak shape with sufficient area.

Additionally, using a T-joint, the injection sample was then divided between two porous layer open tubular capillary columns
115 filled molecular sieve 5A (RT-MSieve 5A 30 m x 0.32 mm x 30 µm; Restek, USA, Cat. No. #19722) and fused silica (Carboxen 1010 PLOT 30 m x 0.53 mm x 30 µm; Supelco, USA, Cat. No. #25467). The dimensions of the columns were selected to achieve a splitting ratio of 1:5, directing most of the sample to the Carboxen 1010 PLOT and BID. Corresponding calculations were performed in Shimadzu AFT (Advanced Flow Technology) software (Fig. 2).

Extremely low baseline noise (signal/noise ratio (S/N) always above 10) was achieved by a combination of two factors: a high
120 purity carrier gas helium grade 5.0 connected to the Valco Helium Purifier HP2 (VICI Valco Instruments Co. Inc.) and particle traps (2.5 m x OD 0.32 mm) mounted on the columns' outlets. The presence of the traps protected the detectors from particles dislodging from the porous layer open tubular (PLOT) capillary column, which can cause spikes.

Both the detectors used are concentration dependent; therefore to obtain the highest sensitivity on the BID channel, the discharge gas flow rate was decreased from a default of 50 mL/min to 30 mL/min, which is the lowest possible flow (Barrier
125 Discharge Ionization Detector for GC-2010 Plus BID-2010 Plus Instruction Manual. Shimadzu Corporation 2013). Below this value the plasma flame is not stable and tends to flicker or extinguish. Detection levels did not need to be taken into consideration with the TCD

The linearity of the both detectors response was controlled and maintained during all the measurements with minimal R²=0.99 applying at least two standard gases and 0 point.

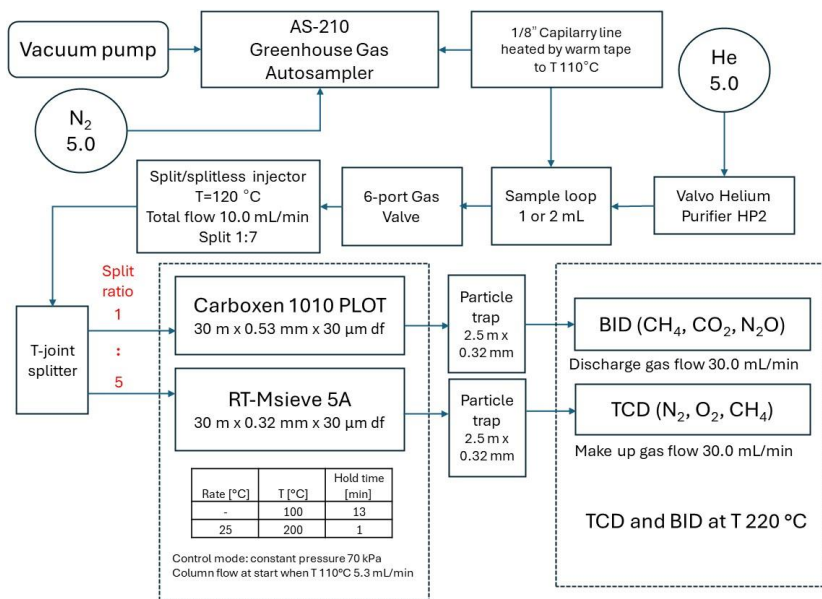

130

Figure 1: Configuration of GC system for measurement of CH₄, CO₂ and N₂O

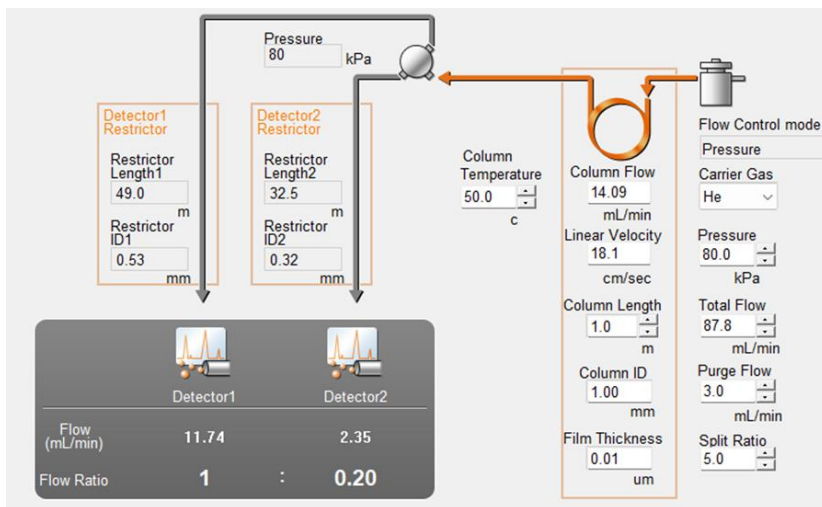

Figure 2: Detailed flow parameters in GC system configuration

2.2 Parameters of the separation and detection methods

135 The temperature programme for gas chromatography analyses started at 100 °C for 13 minutes, and later increased to 200 °C at a rate of 25 °C/min with the oven set at 200 °C for one minute. The temperature of the split/splitless injector was 120 °C. The TCD and BID were at an equal temperature of 220 °C. The carrier gas pressure was 70 kPa and the column flow was 5.3 mL/min. Linear velocity was 41.2 cm/s and purge flow was 1 mL/min. The total flow for split ratios 1, 2, 3, 4 and 5 was 11.5, 16.8, 22.0, 27.3 and 32.5 mL/min, respectively.

2.3 Standard gas mixtures

Standard gas mixtures used for testing and final determination of the measurements precision were atmospheric air from Wrocław (Poland) (analyses of N₂, O₂, CH₄, CO₂ and N₂O at ambient atmospheric concentrations) and a special gas mixture from Messer (CH₄ 10 ppm, CO₂, 1000 ppm, N₂O 50 ppm, diluted in pure N₂). The in-house standard of compressed air from Wrocław (Poland), which contained natural moisture (water vapour), was stored in the 10 litres gas cylinder. It was prepared by oil-free compressor for diving cylinders. The second standard was ordered in Messer Polska Sp. z o.o. and is the commercial product prepared in Switzerland according to the norm ISO6141:2015. This standard was prepared in pure N₂, without moisture, in volume of 8 litres and contains F10 filter, which protects outer valve from the possible water vapour or solid particles. The standards were directly connected by 1/8" capillary to the AS-210 Greenhouse Gas Autosampler. The sample loops used for tests of standard gases were 1 mL and 2 mL. The atmospheric air was tested for splits 1, 2, 3, 4 and 5. The special gas mixture from Messer was tested for splits 3, 4 and 5.

3 Results and Discussion

3.1 Basic testing of the SH-Q-BOND and Carboxen 1010 PLOT columns and BID detector

The chromatographic system for GHG analyses using a single BID was initially tested for application of the SH-Q-BOND column (30 m x 0.53 mm ID x 20 µm df; Cat. No. #221-75765-30) from Shimadzu, which allows for separation of CH₄, CO₂ and N₂O, and is resistant to water vapour contamination. The scheme showing GC configuration for testing of SH-Q-BOND and RT-Msieve 5A is presented in Appendix A (Fig. A1). In this configuration most of the parameters were exactly the same (length of the column, diameter, film thickness, flow parameters, split ratio) as in configuration using Carboxen 1010 PLOT column. The only differences were usage of SH-Q-BOND column for separation of CH₄, CO₂, N₂O and different column oven temperature programme.

Separation of these gases was tested at different low temperatures of the column oven (30 °C, 35 °C and 40 °C). The lowest temperature (30 °C) was difficult to achieve quickly by the oven without using a cryogenic trap. At the laboratory's normal temperature (22 °C), it was possible to decrease the oven temperature rapidly to 35 °C and 40 °C, but unfortunately both temperatures were insufficient to separate CO₂ from N₂O at a retention time interval longer than 30 seconds, which appeared very problematic while analysing real samples of elevated CO₂ concentration. When the CO₂ concentration was high (e.g. 700 ppm), the tail of the CO₂ peak partially covered the N₂O peak, as shown below in Figures 3A and 3B, and ultimately the N₂O peak area was understated. Moreover, this set-up did not allow detection of CH₄ in atmospheric concentrations.

3A

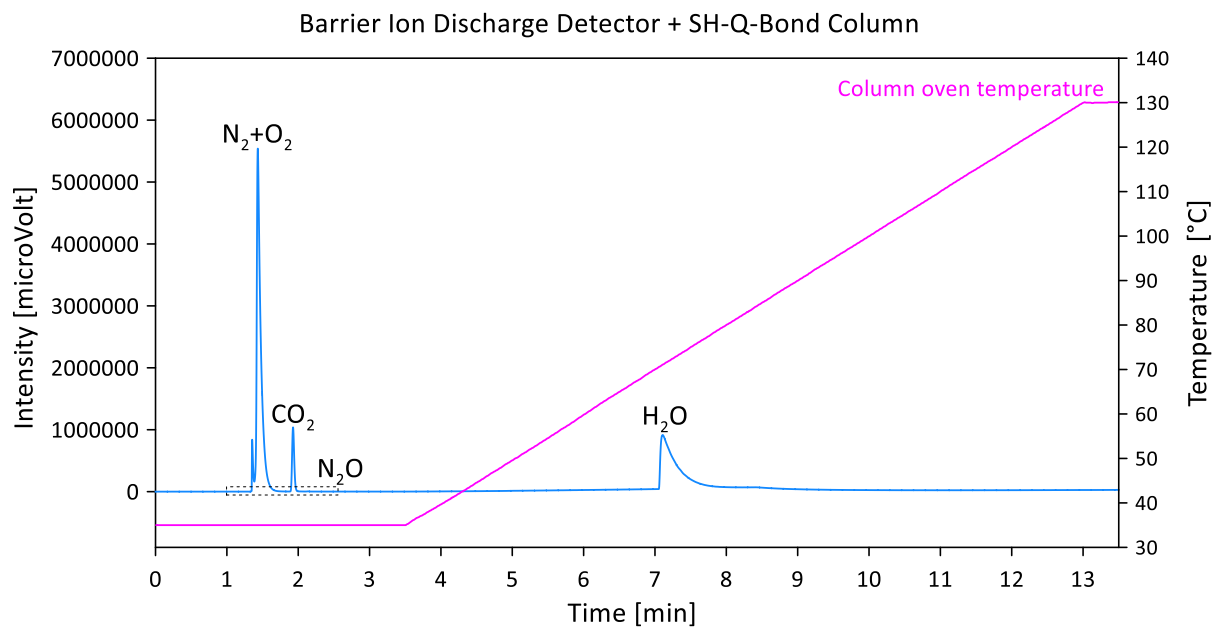

3B

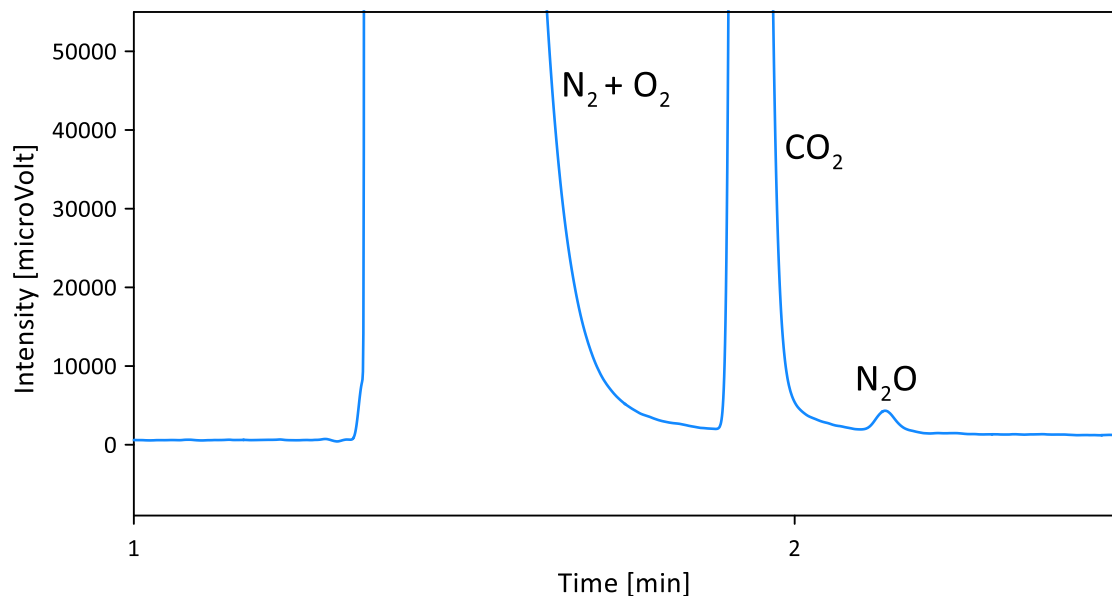

Figure 3: A - Chromatograms of ambient air gases separated using the SH-Q-BOND column and detected using BID;
B - Zoomed chromatogram from Figure 3A

Therefore, after basic tests of the SH-Q-BOND column at different temperatures, it was decided to check the retention times of individual CH₄, CO₂ and N₂O gases on the Carboxen 1010 PLOT column. The Carboxen 1010 PLOT column offered very good separation of CO₂ from N₂O, even at a very high concentration (CO₂ 1000 ppm), as shown in Figure 4 (peaks of CH₄ and N₂O are visible only when zoomed). Moreover, the ambient CH₄ was very well separated from the N₂+O₂ peak (Fig. 4). The longer programme of separation guaranteed the ideal separation of CH₄, CO₂ and N₂O (more than two minutes between each gas). The time of one single analysis is 18 minutes, but this is necessary because a low flow of the carrier gas is recommended for the Carboxen column by its manufacturer. A carrier gas flow that is too high (e.g. above 20 mL/min) causes faster destruction of the column and contamination of the particle trap, and subsequently of the detector, with fragments of the column filling. However, the disadvantage of the application of the Carboxen column is also its low resistance to water vapour. Therefore, before starting the analyses, all lines of the AS-210 Greenhouse Gas Autosampler as well as the sample loop were carefully heated using heating tape and a gun heater to remove water from the stainless steel capillaries and metal parts of the valves. The parallelly connected column Rt-MSieve 5A and TCD allow for determination of N₂ and O₂ (and if necessary CH₄) concentrations in range from 0.2 to 100% (example showed in Fig. 5).

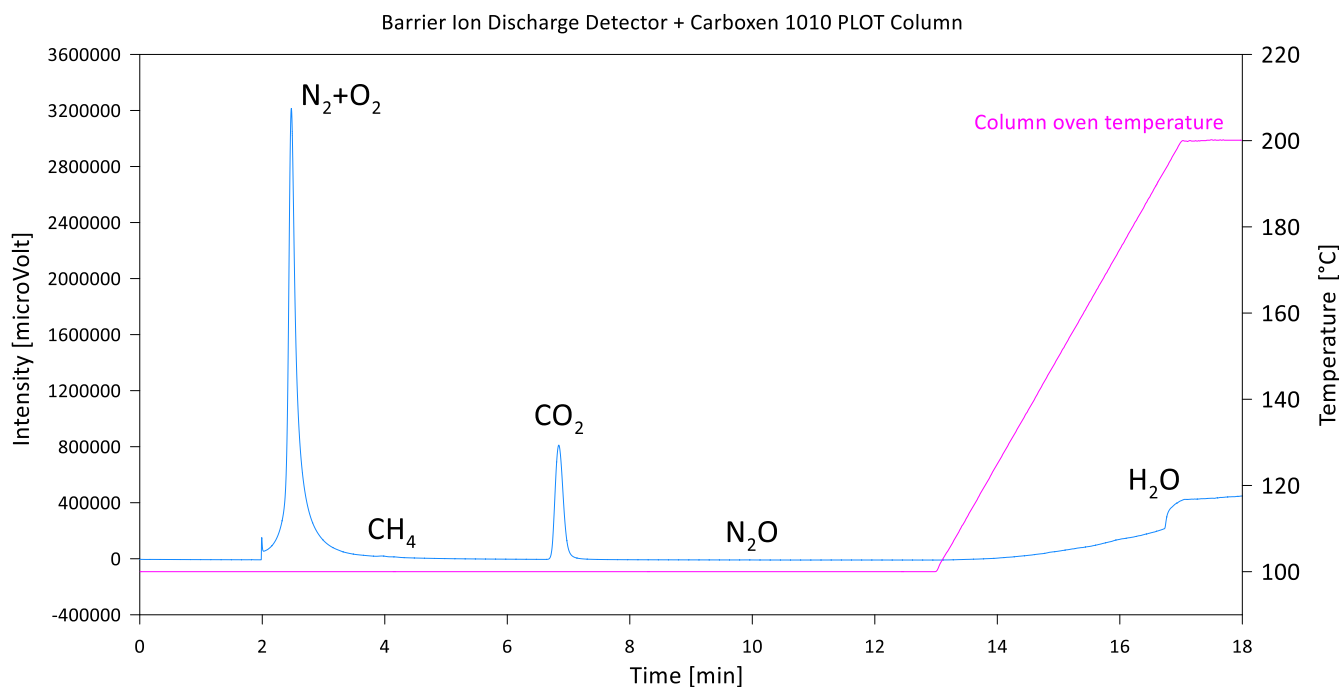
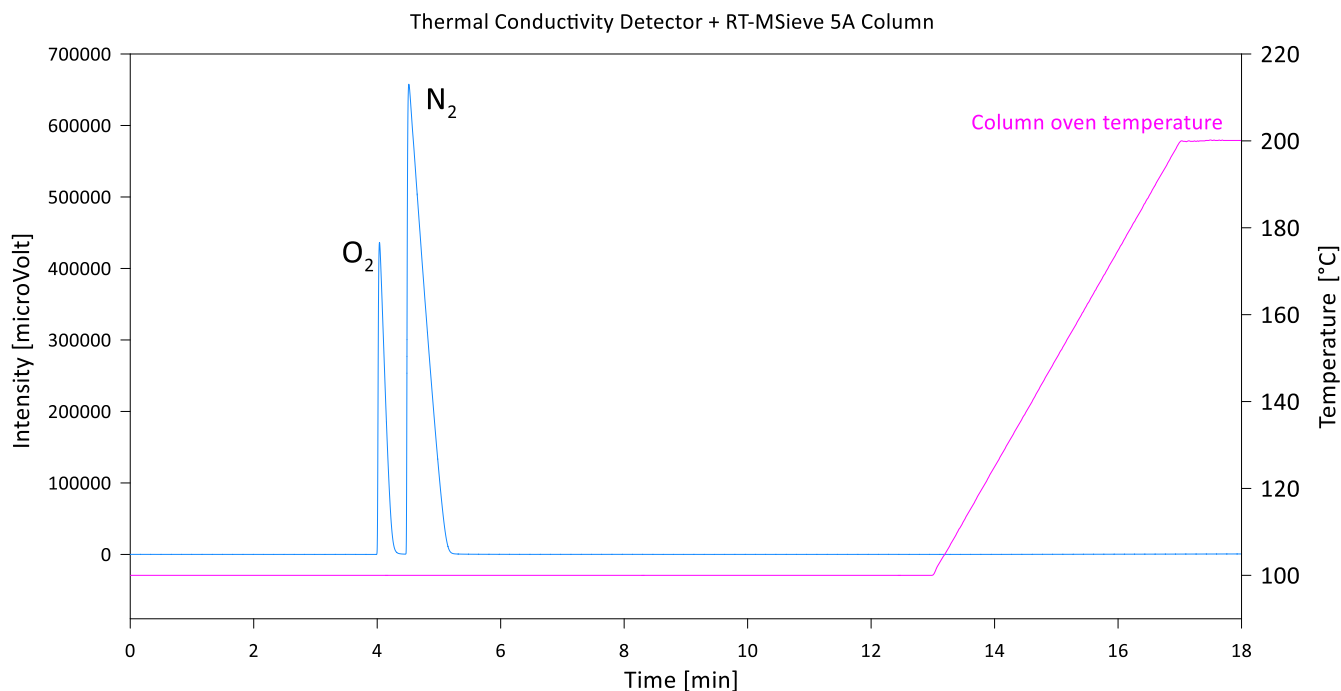

Figure 4: Chromatogram of special gas mixture separated using the Carboxen 1010 PLOT column and detected using BID



190

Figure 5: Chromatogram of ambient air separated using the RT-MSieve 5A column and detected by TCD

3.2 Compressed air standard measurements

The analyses of the compressed air standard with split ratios 1, 2, 3, 4 or 5 and using 1 and 2 mL sample loops showed a different precision, expressed as a coefficient of variation (CV: calculated as the standard deviation divided by the mean value, expressed in %). The CV of the CH₄ measurement (1.895 ppm) was in the range of 3.31 to 8.57 % for the 1 mL sample loop and 1.51 to 2.76 % for the 2 mL sample loop. In the case of CO₂ (411 ppm), the CV ranged from 0.91 to 2.83 % for the 1 mL sample loop and from 0.57 to 1.87 % for the 2 mL sample loop. The CV of the N₂O measurement was lower for the 2 mL sample loop, and ranged from 7.09 to 12.67 %, compared with the 1 mL sample loop where the CV of the N₂O measurement ranged from 9.15 to 20.19 %. Generally, it was observed that gases at low detection limits (CH₄, CO₂) were measured more precisely using the 2 mL sample loop.

Measurement of N₂O in split ratio 3 resulted in a significantly higher CV when compared with the results obtained in split ratios 4 and 5 (Table 1). This is because the injection of a higher amount of water vapour contained in the sample partially covered the peak area of the N₂O (by increasing the baseline level), similarly to the measurement in split ratio 2 (CV 20.19 %). In this case the lower CV at split ratio 1 was only calculated for three measurements to avoid unnecessary contamination of the column.

205

The gases analysed using the TCD, O₂ and N₂, were characterised by a narrow CV ranging from 0.10 to 0.39 %. The highest CV (0.39 %) was observed for the N₂ measurement with the sample loop 2 mL, where the peak area was very large. The results of the measurement (peak area, SD, CV) are presented in Table 1.

210

Table 1: Peak area, SD (standard deviation) and CV (coefficient of variation) of standard atmospheric gas measurements at split ratios 1, 2, 3, 4, and 5 with 1 mL and 2 mL sample loops

Gas	Conc.		Sample loop 1 mL					Sample loop 2 mL		
			Split					Split		
			1	2	3	4	5	3	4	5
		Repetitions	n=3	n=10	n=20	n=20	n=20	n=10	n=20	n=10
CH ₄	1.895 ppm	Area	33294	24249	25271	20085	16269	25535	23758	23195
		SD	2580	802	1859	1365	1394	386	381	640
		CV [%]	7.75	3.31	5.95	6.79	8.57	1.51	1.59	2.76
CO ₂	411 ppm	Area	10900323	8015901	5742835	4525868	3658827	10274295	6900992	6295494
		SD	99092	84289	162281	58578	79062	155997	45587	117747
		CV [%]	0.91	1.05	2.83	1.29	2.16	1.52	0.57	1.87
N ₂ O	339 ppb	Area	7801	4732	3572	2565	2080	5565	4610	3306
		SD	714	955	554	289	323	705	317	329
		CV [%]	9.15	20.19	15.51	11.26	15.55	12.67	7.09	9.95
O ₂	20.946%	Area	4317080	3030077	2147582	1660466	1340040	4513907	3322830	2523219
		SD	9241	5136	7177	4196	2088	10598	3298	7454
		CV [%]	0.21	0.17	0.33	0.25	0.16	0.23	0.11	0.30
N ₂	78.084%	Area	16522678	11587989	8205177	6343410	5119796	17338000	12684872	9709091
		SD	42456	21960	27025	16376	8251	31998	12603	38248
		CV [%]	0.26	0.19	0.33	0.26	0.16	0.15	0.13	0.39

215

3.3 Standard gas mixture measurements

The CH₄, CO₂ and N₂O measurements of the special gas mixture standard at split ratios 3, 4 and 5 were characterised by a repeatable CV within a narrow range from 0.11 to 3.22 %. The CV of the CH₄ measurement (10 ppm) using the 1 mL sample loop ranged from 0.11 to 0.55 %, while for the 2 mL sample loop the CV was in the range of 0.34 to 1.79 %. The CV of CO₂ (1000 ppm) for the 1 mL sample loop was between 2.05 and 3.08 % and for the 2 mL sample loop between 1.57 and 3.22 %. The N₂O measurement (50 ppm), which is a very high concentration (rare in the natural environment), was characterised by a CV in the range of between 0.18 and 0.44 % for the 1 mL sample loop and 0.85 to 2.14 % for the 2 mL sample loop. These

values clearly show that measurements of the gas mixtures with relatively high concentrations of N₂O using BID were repeatable for all splits 3, 4 and 5, and were slightly better using the 1 mL sample loop. However, the application of the sample loops (1 and 2 mL) at split ratios 3, 4 and 5 guaranteed the achievement of repeatable results. Table 2 shows all the data of the standard gas mixture testing measurements.

Table 2: Peak area, SD (standard deviation) and CV (coefficient of variation) of special gas mixture measurements at split ratios 3, 4, and 5 with sample loops 1 mL and 2 mL

Gas	Conc.		Sample loop 1 mL			Sample loop 2 mL		
			Split			Split		
			3	4	5	3	4	5
		Repetitions	n=5	n=4	n=3	n=10	n=10	n=10
CH ₄	10 ppm	Area	149922	118357	96007	278296	207227	161265
		SD	831	133	318	1067	707	2895
		CV [%]	0.55	0.11	0.33	0.38	0.34	1.79
CO ₂	1000 ppm	Area	13522596	11079679	8993195	21485425	17323467	13525917
		SD	331786	341314	184053	337763	331554	435439
		CV [%]	2.43	3.08	2.05	1.57	1.91	3.22
N ₂ O	50 ppm	Area	629251	497331	402025	1171624	867747	673486
		SD	2801	1782	729	9975	11510	14360
		CV [%]	0.44	0.36	0.18	0.85	1.33	2.14

3.4 Direct measurement of ambient laboratory air using the AS-210 Greenhouse Gas Autosampler

Another testing of the GC system was carried out with the application of splits 3, 4 and 5 and sample loop 2 ml (Table 3). The ambient air from the laboratory on one day was analysed directly from the AS-210 Greenhouse Gas Autosampler (empty plate for vials, which enabled direct sampling of the ambient air from the needle to the line connected with the GC's sample loop). The tests were performed with splits 3, 4 and 5 (splits 1 and 2 were omitted to avoid excessive introduction of air containing natural moisture into the Carboxen column).

The CV of CH₄ was in the range of 3.40 to 4.10 % (the highest value for split 4). The CV of CO₂ was in range of 1.31 to 2.29 %, whereas for N₂O it was between 3.11 and 4.04 %. These CV values are close to the results obtained during measurements of the compressed air standard (Section 3.3, Table 1). The difference between the two experiments is that compressed air always had the same composition and gas concentrations, whereas the CH₄ and CO₂ concentrations in ambient air could change slightly over time (daily variability).

Table 3: Peak area, SD (standard deviation) and CV (coefficient of variation) of direct measurements of laboratory air at split ratios 3, 4, and 5 with sample loop 2 mL

Gas	Conc.		Sample loop 2 mL		
			Split		
			3	4	5
		Repetitions	n=20	n=20	n=20
CH ₄	1.895 ppm	Area	27007	24994	23355
		SD	919	1047	957
		CV [%]	3.40	4.19	4.10
CO ₂	411 ppm	Area	8297069	6787524	5351342
		SD	190315	89672	97529
		CV [%]	2.29	1.31	1.82
N ₂ O	339 ppb	Area	5736	4479	3359
		SD	232	139	111
		CV [%]	4.04	3.11	3.31
O ₂	20.946%	Area	4466737	3319922	2493245
		SD	6357	4415	4366
		CV [%]	0.14	0.13	0.17
N ₂	78.084%	Area	17054807	12671953	9517713
		SD	23464	15061	15702
		CV [%]	0.14	0.12	0.16

3.5 Experimental measurement series comparing the GC results with the reference method (Picarro analyser)

To verify the long-term stability of the measurements and the system performance for real samples, a 55-hour-long measurement series of ambient laboratory air was performed. The subsequent air samples were measured in parallel with the GC setup and with the optical instruments dedicated to analyses of GHG concentrations and isotopic signatures (Picarro G5131-i for isotopic N₂O and Picarro G2201-i for CO₂ and CH₄) (Picarro, Santa Clara, USA). The reference methods were applied to check whether slight changes in GHG concentrations over the day/night period can be monitored well with this GC system. The reference instruments – isotopic Picarro – showed a quite narrow range of possible concentration measurements (Picarro G5131-i isotopic N₂O up to 2000 ppb, Picarro G2201-i up to 2000 ppm CO₂ and up to 12 ppm CH₄) but a very high precision for ambient concentrations, without the need for calibration. Therefore they served here as an ideal reference method. During this 55-hour time series, the Picarro measurement was performed every three minutes and the GC measurement every 19 minutes. For GC measurements, split 4 was applied. The concentration trends for CO₂ and CH₄ were observed to be generally in good agreement and the N₂O concentration was very stable (Fig. 6). Importantly, it was observed for CO₂ that after 24 hours the measurements were slightly recalibrated and shifted in relation to the reference method. This indicates the

260 need for repeated calibration at least every 24 hours, especially for CO₂. However, even without recalibration, the maximum
difference between the GC measurement and the reference value was below 3 % for both CO₂ and CH₄. The largest variations
in the GC results were observed for N₂O, especially when comparing them to the very stable Picarro measurements. This is
the most challenging analysis, since N₂O ambient concentrations are lowest and hardest to measure correctly. The maximum
265 difference between the GC measurement and the reference value for N₂O was around 8 % and the standard deviation of GC
measurements was 15 ppb, which represents a 4.4 % error. This is quite high when compared with Picarro statistics where the
standard deviation over 55 hours of measurement was 0.24 ppb, which represents less than 0.1 % error. However, for typical
N₂O measurements of unknown sample with GC techniques, a 5 % error is a satisfactory result, typically given as an accepted
GC measurement error in research studies (Arnold et al., 2001; Harvey et al., 2020). The precision obtained for ambient air
measurements is similar for CO₂ and CH₄ compared with classical FID measurements, with an error of around 2 % (Loftfield
270 et al., 1997), but is lower when compared with ECD measurements, for which a 1.2 % error has been reported (Loftfield et al.,
1997). Usually systems that enable the simultaneous measurement of CH₄ and CO₂ are very accurate, but the main limitation
is the upper detection limit. For example, Wang and Wang (2003) achieved a CH₄ precision error in a range from 3.37 %
(ambient concentration) to 0.05 % (60 ppm), or for CO₂ from 0.66 % (ambient concentration) to 0.04 % (4000 ppm). In the
present system, higher concentrations of CH₄ can be measured by the TCD simply using a RT-Msieve 5A column. The
275 chromatographic system can be improved by the addition of a second gas valve aimed at transferring CO₂ to the TCD after
separation using the Carboxen column. This would allow further improvement of this chromatographic system for the
maximum range of measured GHG concentrations.

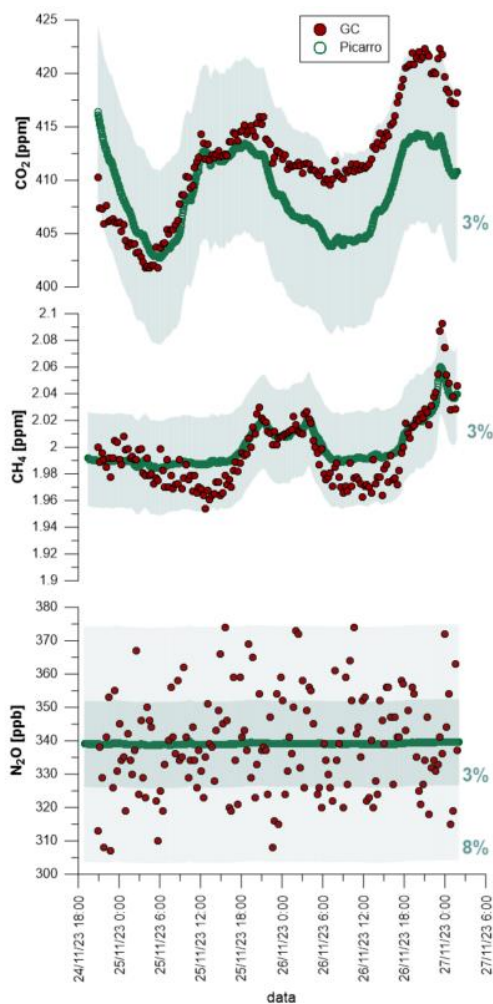

280 **Figure 6: Comparison of CH₄, CO₂ and N₂O variations in ambient air measured using a Picarro analyser and the GC system**

4. Conclusions

This article outlined a simple method for determination of CH₄, CO₂ and N₂O concentrations from ambient air. The main advantage is that the use of at least two separate detectors can be avoided, including the ECD that contains radioactive materials, and FID with methaniser to measure CO₂. A single column Carboxen 1010 PLOT can be successfully used for separation of GHG (CH₄, CO₂, N₂O) in time interval enabling measurement of each gas separately without the effect of peak overlapping. In parallel a connected Rt-MSieve 5A column allows for determination of higher CH₄ concentrations as well control of the O₂ and N₂ concentrations in the sample. The main disadvantage of the method is the lack of direct measurement of samples with high CO₂ concentrations (above 4000 ppm) in the set-up presented here, which is the upper detection limit for the BID. In summary the detection limits of simplified GC system are: CH₄ 1.8 ppm-100%, CO₂ 411-4000 ppm, N₂O 339-

285

290 4000 ppm, O₂ 0.2-100%, N₂ 0.2-100%. Further reconstruction with an additional valve directing the separated CO₂ to the TCD would allow additional analyses of higher CO₂ concentrations.

Based on performed tests, it is recommended that atmospheric GHGs are analysed using a BID at split ratio 4 or 5 and with a sample loop of 2 mL volume. This would help avoid unnecessary contamination of the Carboxen column with water vapour, therefore splits 1-3 should not be considered for the measurement of environmental gas samples. In this chromatography system, the CV of N₂O measurement at atmospheric level was 11-15 % (sample loop 1 mL), and around 7-9 % (when using the 2 mL sample loop), CV of CH₄ measurement at atmospheric level was near 7 % (sample loop 1 mL), and below 3 % (when using the 2 mL sample loop), CV of CO₂ measurement at atmospheric level was near 2 % (sample loop 1 mL), and around 1.5 % (when using the 2 mL sample loop). The diurnal variations for CO₂ and CH₄ can be monitored well with the precision below 3% error, whereas for N₂O measurements 8% error must be taken into account.

300 The presented results for the measurement precision are satisfactory for the most analytical needs for determining GHG fluxes in field studies or laboratory incubation experiments. However, this GC system is not designed for the most precise analyses at ambient concentration and monitoring daily changes or long-term periods. Its measurement accuracy is not sufficient for such purposes when compared with instruments using optical techniques or automated GC systems dedicated for GHG at ambient air concentration. The greatest advantage of proposed GC system is the ability to measure GHGs at the widest possible concentration, from the near-ambient concentrations to 100%, and in any sample matrix, without the risk of damaging or decalibration of the equipment. It is easy to use and relatively cheap. Therefore, it can be successfully used for analyses of the gas samples with unknown GHG concentrations e.g. from soil chamber measurements, laboratory incubation studies, biogas plants, waste dumps, burning coal heaps, mines, or monitoring of environmental GHGs fluxes.

310 **Authors contributions:**

MB and PW constructed the analytical set-up, MB and DLS planned the measurement campaign; MB, DLS and PW performed the measurements; MB and DLS analyzed the data; MB, DLS, and PW wrote the manuscript draft; MB, DLS and PW reviewed and edited the manuscript..

315 **Competing interests:**

The authors declare that they have no conflict of interest.

Funding:

This study was financially supported by the “Polish Returns” programme of the Polish National Agency of Academic Exchange and the grant Opus No. 2021/41/B/ST10/01045 funded of the National Science Centre Poland.

References

- Arnold, S.L., Parkin, T.B., Doran, J.W., Eghball, B., Mosier, A.R., 2001. Automated gas sampling system for laboratory analysis of CH₄ and N₂O. *Commun. Soil Sci. Plant Anal.* 32, 2795–2807. <https://doi.org/10.1081/CSS-120000962>
- Barrier Discharge Ionization Detector for GC-2010 Plus BID-2010 Plus Instruction Manual. Shimadzu Corporation 2013
- 325 Ekeberg, D., Ogner, G., Fongen, M., Joner, E.J., Wickstrøm, T., 2004. Determination of CH₄, CO₂ and N₂O in air samples and soil atmosphere by gas chromatography mass spectrometry, GC-MS. *J. Environ. Monit.* 6, 621–623. <https://doi.org/10.1039/b401315h>
- Fastyn, P., Kornacki, W., Kardaś, M., Gawłowski, J., Niedzielski, J., 2003. Adsorption of water vapour from humid air in carbon molecular sieves: Carbosieve S-III and Carboxens 569, 1000 and 1001. *Analyst* 128, 198–203. <https://doi.org/10.1039/b209296d>
- 330 Gruca-Rokosz, R., Szal, D., Bartoszek, L., Pękala, A., 2020. Isotopic evidence for vertical diversification of methane production pathways in freshwater sediments of Nielisz reservoir (Poland). *Catena* 195, 104803. <https://doi.org/10.1016/j.catena.2020.104803>
- Harvey, M.J., Sperlich, P., Clough, T.J., Kelliher, F.M., McGeough, K.L., Martin, R.J., Moss, R., 2020. Global Research Alliance N₂O chamber methodology guidelines: Recommendations for air sample collection, storage, and analysis. *J. Environ. Qual.* 49, 1110–1125. <https://doi.org/10.1002/jeq2.20129>
- 335 Hedley, C., Saggari, S., Tate, K., 2006. Procedure for fast simultaneous analysis of the greenhouse gases: Methane, carbon dioxide, and nitrous oxide in air samples. *Commun. Soil Sci. Plant Anal.* 37, 1501–1510. <https://doi.org/10.1080/00103620600709928>
- 340 Lamb, W.F., Wiedmann, T., Pongratz, J., Andrew, R., Crippa, M., Olivier, J.G.J., Wiedenhofer, D., Mattioli, G., Khourdajie, A. Al, House, J., Pachauri, S., Figuerola, M., Saheb, Y., Slade, R., Hubacek, K., Sun, L., Ribeiro, S.K., Khennas, S., De La Rue Du Can, S., Chapungu, L., Davis, S.J., Bashmakov, I., Dai, H., Dhakal, S., Tan, X., Geng, Y., Gu, B., Minx, J., 2021. A review of trends and drivers of greenhouse gas emissions by sector from 1990 to 2018. *Environ. Res. Lett.* 16. <https://doi.org/10.1088/1748-9326/abee4e>
- 345 Lofthfield, N., Flessa, H., Augustin, J., Beese, F., 1997. Automated Gas Chromatographic System for Rapid Analysis of the Atmospheric Trace Gases Methane, Carbon Dioxide, and Nitrous Oxide. *J. Environ. Qual.* 26, 560–564. <https://doi.org/10.2134/jeq1997.00472425002600020030x>
- Rapson, T.D., Dacres, H., 2014. Analytical techniques for measuring nitrous oxide. *TrAC - Trends Anal. Chem.* 54, 65–74. <https://doi.org/10.1016/j.trac.2013.11.004>
- 350 Scion Instruments, 2023. Analysis of Greenhouse Gas by Gas Chromatography.
- Shimbo, E., Uchiyama, S., 2022. Application News: Simultaneous Analysis of Three Greenhouse Gas Components, CH₄, CO₂, and N₂O.
- van der Laan, S., Neubert, R.E.M., Meijer, H.A.J., 2009. single gas chromatograph for accurate atmospheric mixing ratio

measurements of CO₂, CH₄, N₂O, SF₆ and CO. *Atmos. Meas. Tech.* 2, 549–559. <https://doi.org/10.5194/amt-2-549-2009>

355 Wang, Yuesi, Wang, Yinghong, 2003. Emissions from a Short-Plant Ecosystem. *Adv. Atmos. Sci.* 20, 842–844.
<https://dx.doi.org/10.1007/BF02915410>

Zaman, M., Kleineidam, K., Bakken, L., Berendt, J., Bracken, C., Butterbach-Bahl, K., Cai, Z., Chang, S.X., Clough, T.,
Dawar, K., Ding, W.X., Dörsch, P., dos Reis Martins, M., Eckhardt, C., Fiedler, S., Frosch, T., Goopy, J., Görres, C.-
M., Gupta, A., Henjes, S., Hofmann, M.E.G., Horn, M.A., Jahangir, M.M.R., Jansen-Willems, A., Lenhart, K., Heng,
360 L., Lewicka-Szczebak, D., Lucic, G., Merbold, L., Mohn, J., Molstad, L., Moser, G., Murphy, P., Sanz-Cobena, A.,
Šimek, M., Urquiaga, S., Well, R., Wrage-Mönnig, N., Zaman, S., Zhang, J., Müller, C., 2021. Methodology for
Measuring Greenhouse Gas Emissions from Agricultural Soils using Non-Isotope techniques. 11-209. In: Zaman M,
Kleineidam K, Bakken L, Berendt J, Bracken C, Butterbach-Bahl K, Cai Z, Chang SX, Clough T, Dawar K, Ding WX,
Dörsch P, dos Reis Martins M, Eckhardt C, Fiedler S, Frosch T, Goopy J, Görres C-M, Gupta A, Henjes S, Hofmann
365 MEG, Horn MA, Jahangir MMR, Jansen-Willems A, Lenhart K, Heng L, Lewicka-Szczebak D, Lucic G, Merbold L,
Mohn J, Molstad L, Moser G, Murphy P, Sanz-Cobena A, Šimek M, Urquiaga S, Well R, Wrage-Mönnig N, Zaman S,
Zhang J, Müller C (2021) Measuring Emission of Agricultural Greenhouse Gases and Developing Mitigation Options
Using Nuclear and Related Techniques Springer ISBN 978-3-030-55395-1, [https://doi.org/10.1007/978-3-030-55396-](https://doi.org/10.1007/978-3-030-55396-8)

8

370